

Lines, Angles, & Shapes: Measuring Our World

Part Two

Fast Track GRASP Math Packet

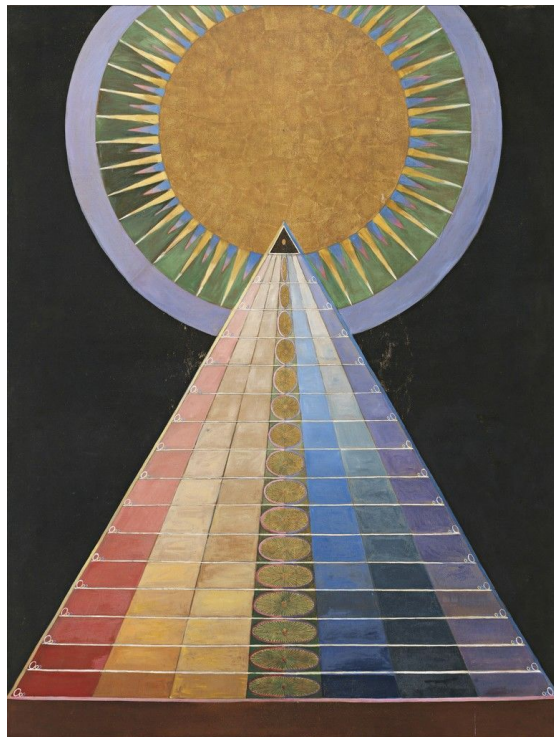

Hilma af Klint, Group X, No. 1, Altarpieces (1915)

Version 1.2

Released 5/14/2019



This Fast Track GRASP Math Packet was made possible through support from the New York State Education Department, Office of Adult Career and Continuing Education Services. The Fast Track GRASP Math packets use a Creative Commons license of Attribution-NonCommercial 4.0 International (CC BY-NC 4.0), which means that they can be shared, copied and redistributed in any form, as long as the document retains attribution to CUNY/NYSED for their creation.



Table of Contents

Welcome!	3
Language Practice	4
Using Graphic Organizers to Learn Vocabulary	4
Families of Shapes	7
Quadrilaterals	9
Building Squares	12
Families of Shapes - Answer Key	17
Triangles	20
Right Triangles	21
The Pythagorean Theorem	23
Triangles - Answer Key	33
Scale, Dilation, and Similarity	35
Scale, Dilation, and Similarity - Answer Key	49
Circles	51
Circles - Answer Key	57
Test Practice Questions	58
Test Practice Questions - Answer Key	68
Reviewing What We Have Learned About Lines, Angles, and Shapes	70
The Language of Geometry	71
Concept Circle	71
Geometry in Your Life	73
Glossary and Vocabulary Review	76

Welcome!

Congratulations on deciding to continue your studies! We are happy to share this study packet on polygons, similar shapes, circles, triangles, and the Pythagorean Theorem. We hope that these materials are helpful in your efforts to earn your high school equivalency diploma. This group of math study packets will cover mathematics topics that we often see on high school equivalency exams. If you study these topics carefully, while also practicing other basic math skills, you will increase your chances of passing the exam.

Please take your time as you go through the packet. You will find plenty of practice here, but it's useful to make extra notes for yourself to help you remember. You will probably want to have a separate notebook where you can recopy problems, write questions and include information that you want to remember. Writing is thinking and will help you learn the math.

After each section, you will find an answer key. Try to answer all the questions and then look at the answer key. It's not cheating to look at the answer key, but do your best on your own first. If you find that you got the right answer, congratulations! If you didn't, it's okay. This is how we learn. Look back and try to understand the reason for the answer. Please read the answer key even if you feel confident. We added some extra explanation and examples that may be helpful. If you see a word that you don't understand, try looking at the *Vocabulary Review* at the end of the packet.

We also hope you will share what you learn with your friends and family. If you find something interesting in here, tell someone about it! If you find a section challenging, look for support. If you are in a class, talk to your teacher and your classmates. If you are studying on your own, talk to people you know or try searching for a phrase online. Your local library should have information about adult education classes or other support. You can also find classes listed here: <http://www.acces.nysed.gov/hse/hse-prep-programs-maps>

You are doing a wonderful thing by investing in your own education right now. You have our utmost respect for continuing to learn as an adult.

Please feel free to contact us with questions or suggestions.

Best of luck!

Eric Appleton (eric.appleton@cuny.edu) & Mark Trushkowsky (mark.trushkowsky@cuny.edu)
CUNY Adult Literacy and High School Equivalency Program

Language Practice

Using Graphic Organizers to Learn Vocabulary

In order to learn math vocabulary, we need practice using words in different ways. In this activity, you will choose a few words from this packet that you want to practice, then you will complete a graphic organizer for each word. Look at the sample for the word *quotient* below.

To start, choose a word from the packet and complete the graphic organizer:

- **What is the definition of the word?** You can look at the vocabulary review on page 74 for help. Write the definition in your own words to really make the word yours.
- **Make a visual representation.** You can make a drawing or diagram that will help you remember what the word means.
- **What are some examples of the word you're studying?** Below you can see that there are examples of *quotients*, which are the answers to division problems.
- **What are some non-examples of this word?** These are things that are **not** the word you're studying. For example, 24 is **not** the quotient of 4 divided by 6.

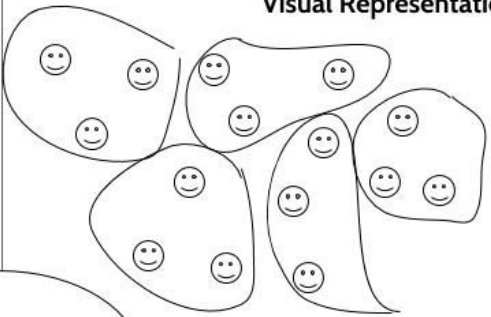
<p>What is it?</p> <p>A quotient is the result of dividing one number by another. It is the answer to a division question.</p>	<p>Visual Representation</p> 
<p>What are some examples?</p> <p>15 divided by 3 equals 5</p> <p>$66 \div 6 = 11$</p> <p>$63/18 = 3.5$</p> <p>5, 11 and 3.5 are quotients in these calculations.</p> <p>population \div area = density</p>	<p>What are some non-examples?</p> <p>4 times 6 equals 24</p> <p>$18 + 5 = 23$</p> <p>$17 - 2.5 = 14.5$</p> <p>$3.5 \times 18 = 63$</p>

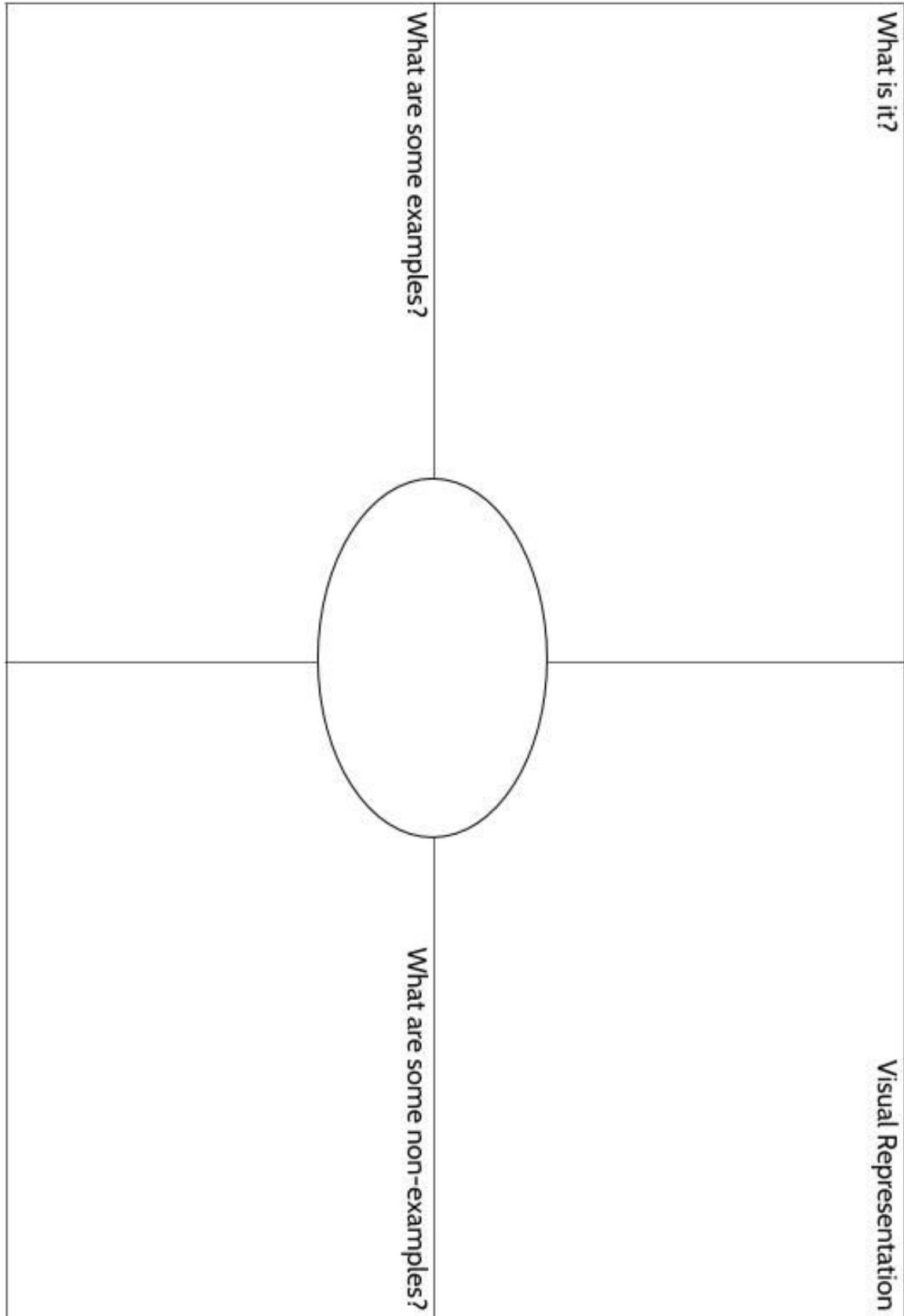

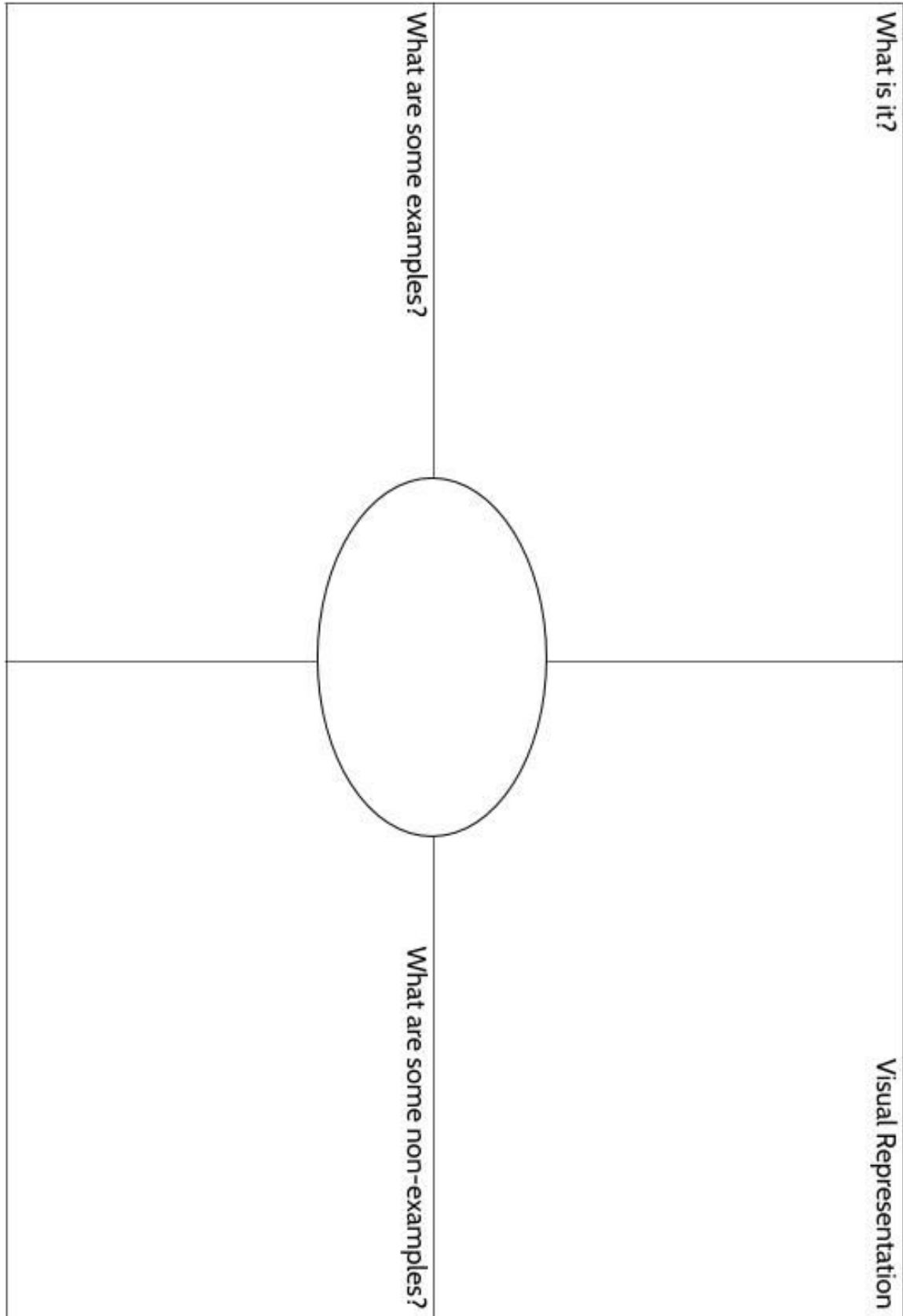

Families of Shapes

The world is full of shapes. There are so many possible shapes it is difficult to talk about them without breaking all of those shapes into “families.”

The first “family” of shapes we will look at are called polygons. Polygons are shapes that are formed by straight line segments so that each line segment meets exactly two other segments.

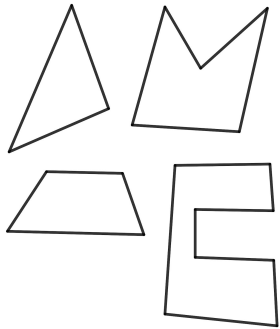
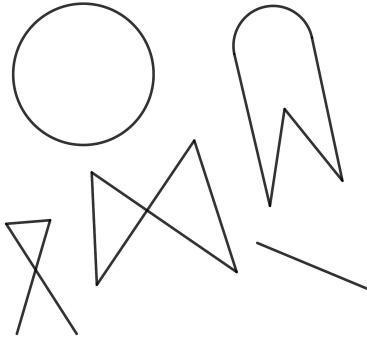
Some examples of polygons	Some examples of shapes that are not polygons
	

We can break polygons into smaller families based on the number of sides the polygon has.

Number of Sides	Name
3	Triangle
4	Quadrilateral
5	Pentagon
6	Hexagon
7	Heptagon
8	Octagon
9	Nonagon
10	Decagon

Lines, Shapes, & Angles: Measuring Our World (Part 2)

1) You can find examples of polygons in the pictures below. Under each photo, write the name of any polygons you see:



a.



b.



c.



d.



e.



f.

Quadrilaterals

A **Quadrilateral** is any polygon with 4 sides and 4 angles. Within the quadrilateral family, there are smaller families. The chart below shows four common types of quadrilaterals - the parallelogram, the rhombus, the rectangle, and the square.

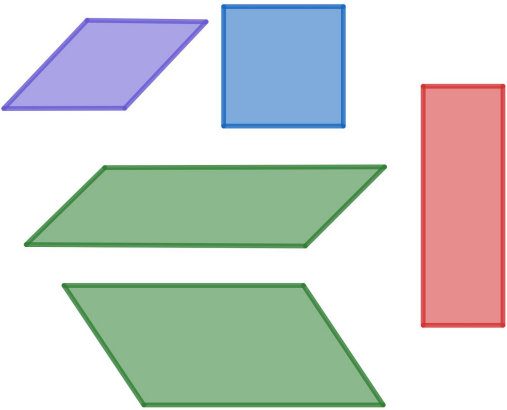
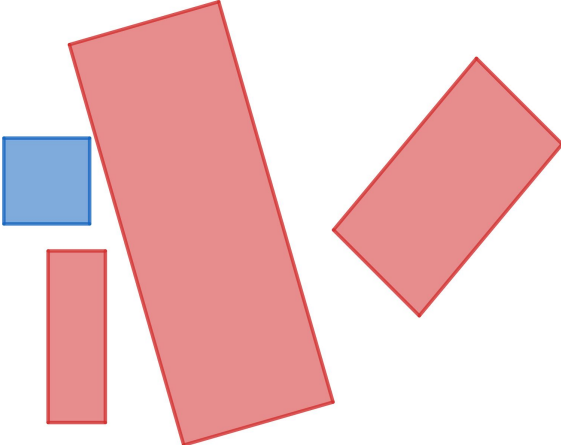
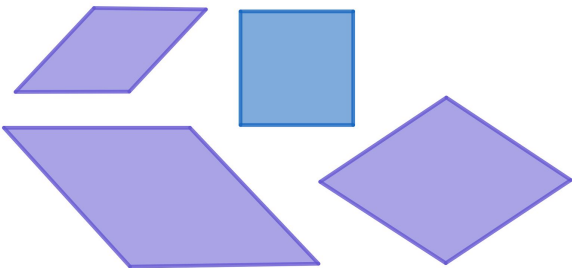
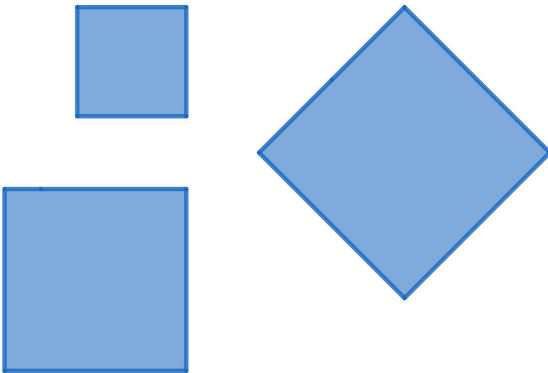
Some Common Quadrilaterals	
<p>Parallelograms</p> 	<p>Rectangles</p> 
<p>Rhombi (rhombi is plural for more than one rhombus)</p> 	<p>Squares</p> 

What relationship do you notice between these 4 types of quadrilaterals? What do they all have in common? How are they different?

Lines, Shapes, & Angles: Measuring Our World (Part 2)

- 2) To answer these questions, let's gather some data. Below you will see a chart with the quadrilaterals. The first column has a list of characteristics. If that characteristic is always true for any of the 4 quadrilaterals, write an "X." For example, for all parallelograms, opposite sides must be parallel, so we wrote an "X" under "Parallelogram."

Use the pictures on the previous page to complete the rest of the chart.

Defining Characteristics	Parallelogram	Rhombus	Rectangle	Square
Number of sides	4	4	4	4
Number of angles	4	4	4	4
Opposite sides are parallel	X			
Opposite sides are the same length				
4 right angles				
All sides are the same length				

Once you have completed your chart, look down each column, and review the characteristics that define each quadrilateral. If a figure meets the characteristics in any column, it is considered to belong to that family of quadrilateral.

- 3) Which of the following statements is not true?
- a) All squares are rectangles.
 - b) All parallelograms are rectangles.
 - c) All rectangles are parallelograms.
 - d) Some rectangles are squares.

Explain your answer. _____

Of these four quadrilaterals, the parallelogram is the easiest family to be a part of. Any shape that has 4 sides, 4 angles, and opposite sides that are parallel and equal in length is a parallelogram.

If a figure meets the characteristics of a parallelogram, and has right angles, it is also considered a rectangle. This means that a figure can be a parallelogram and a rectangle. A rectangle is a special kind of parallelogram.

If a figure meets the characteristics of a parallelogram and has 4 sides that are equal in length, it is also considered a rhombus. A figure can be a parallelogram and a rhombus at the same time. A rhombus is another special kind of parallelogram.

Of these four quadrilaterals, the square is has the most defining characteristics.

- A square is a special rhombus with right angles.
- A square is a special rectangle with 4 equal sides.

So, a square is also considered a parallelogram, a rhombus, and a rectangle.

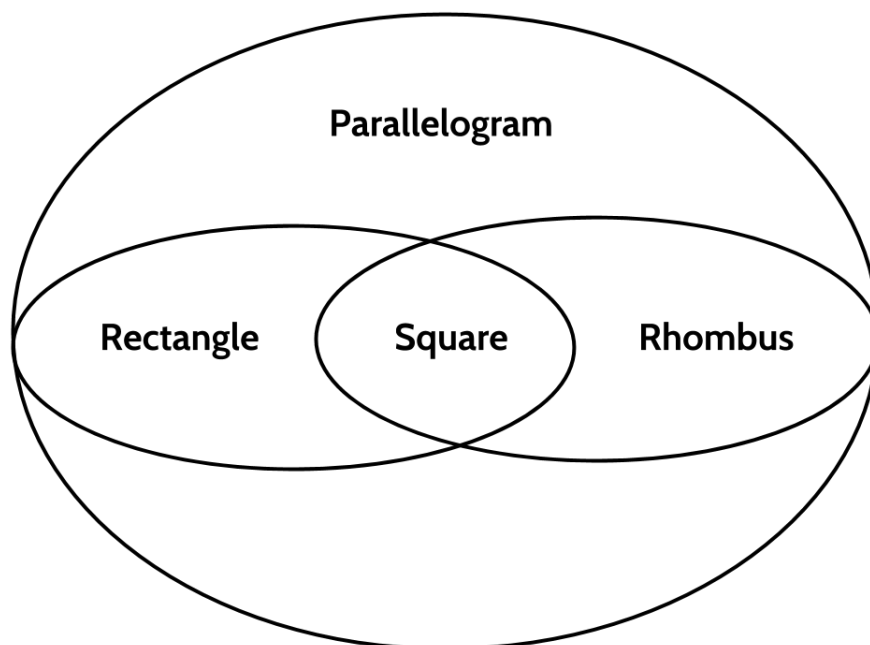

Building Squares

In **The Power of Exponents (Part 1)**, you learned about raising numbers to the power of two and of finding the square root of numbers.

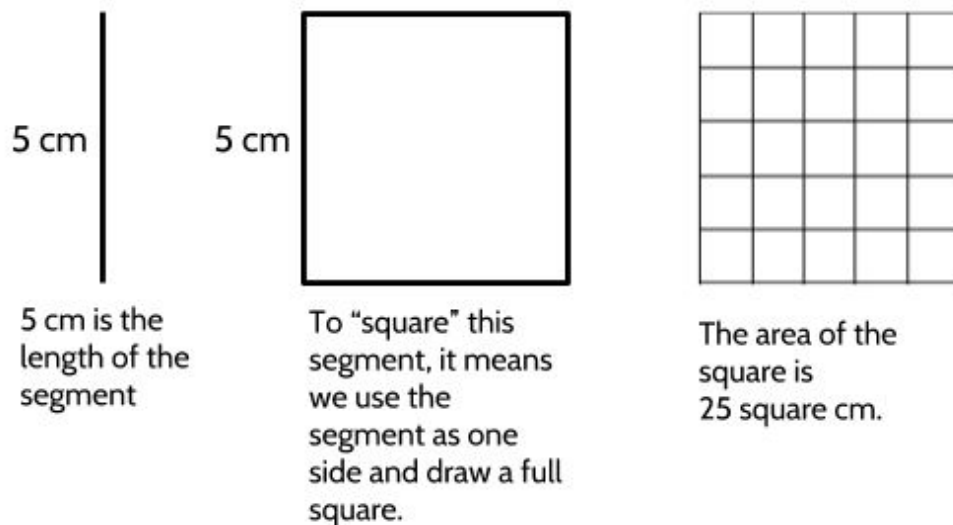

Five “squared” equals 25.

$$5^2 = 25$$

$$5 \times 5 = 25$$

- 4) Find the area of a square whose sides each measure 9 cm.

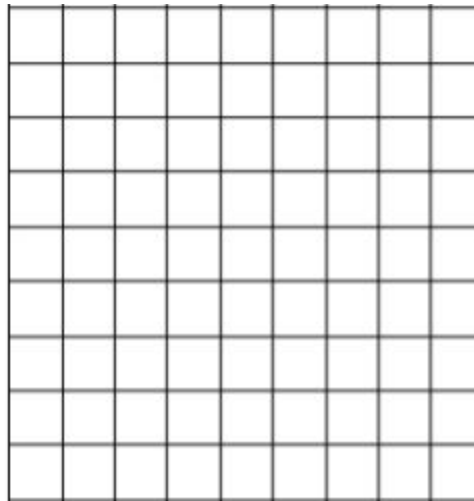

We can also go the other way. Starting with a square, we can figure out the length of one side of that square. The length of that side is called the *square root*.

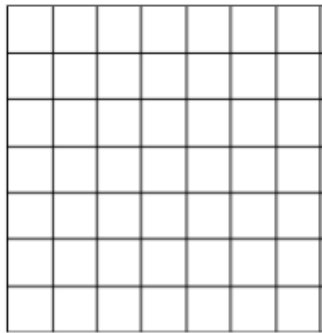

The area of this square is 49 square cm.



What is the length of one side of this square?

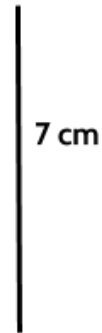

We can write this as $7^2 = 49$, which can be read as “7 squared equals 49,”

OR

We can write $\sqrt{49} = 7$ which is read as “The square root of 49 is 7.”

Sometimes we need to figure out the square root of a number that is too big to draw. There are a few ways we can do that.

Let’s say we want to find the square root of 441. Another way to say this is: If we have a square with an area of 441 square centimeters, what is the length of one side of the square? To find the square root of a number we can ask, “What number times itself would give me the original number?” Especially if you have a calculator, this strategy of guess-and-check can be quick.

Try a few different guesses to see how many tries it takes you to find what number times itself is 441. Record each attempt in the space below. After each attempt, ask yourself, “Should my next guess be smaller or larger than the number I just tried?”

Guess (Square Root)	Number Squared
12	144

Guess (Square Root)	Number Squared

Another strategy is to use the square root function on a calculator. Depending on the calculator, you will use one of the following buttons:



On most calculators, you will see a button that looks something like this. Enter the number that represents the area of the square and then press this button. The calculator should display the square root.



If you have a smartphone, you also have a square root button, but it looks a little different. Go into the calculator mode. Then turn your phone on its side and you will see more options. One of them will look like the symbol above. Enter the number first and then press the button.



With the TI-30XS, the calculator you will use for the HSE exam, you will need to take an extra step. Notice that the square root symbol is printed above the x^2 button. You will need to press the **2nd** button...



... and then x^2 to tell the calculator to use the function written above the button.

Another difference is you need to enter the square root symbol first. So to find the square root of 144, press



, 144, then enter.

5) Use a calculator to find the square root of the following numbers.

Number	Square Root
36	
625	
1225	
.25	
250,000	
Try your own:	

6) Complete this chart.

Length of one side of the square	Length of one side squared	Area of the square
3	3^2	9
4	4^2	
5	5^2	
6	6^2	
7	7^2	
8	8^2	
9	9^2	
10	10^2	
11	11^2	
12	12^2	
13	13^2	
14	14^2	
15	15^2	
16	16^2	
17	17^2	
18	18^2	
19	19^2	
20	20^2	

7) Find the square root of each of the following numbers:

- a) The square root of 576 is _____ .
- b) If the area of a square is 625, the length of one side of the square is _____ .
- c) What number times itself is 729? _____
- d) _____ \times _____ = 900.
- e) The square root of 1024 is _____ .

8) How many different polygons can you find in the image below?



In the space below, redraw each polygon you find and label it with its name.

Families of Shapes - Answer Key

1) Photos of polygons

- a) The beehive is made up of hexagons.
- b) The Pentagon is the headquarters of the US Department of Defense—it is named for the shape of the building. Within the pentagon, you might also see quadrilaterals and triangles.
- c) Stop signs are octagons.
- d) The areas of land are divided up into quadrilaterals.
- e) The coin from the Philippines is in the shape of a decagon.
- f) This window from the Yuyuan gardens in Shanghai, China is a heptagon.

2) The characteristics of quadrilaterals

Defining Characteristics	Parallelogram	Rhombus	Rectangle	Square
Number of sides	4	4	4	4
Number of angles	4	4	4	4
Opposite sides are parallel	X	X	X	X
Opposite sides are the same length	X	X	X	X
4 right angles			X	X
All sides are the same length		X		X

- 3) Choice B. All of the statements are true except that “All parallelograms are rectangles.” A shape can be a parallelogram if it has 4 sides and 4 angles and opposite sides that are parallel and equal in length. To be a rectangle, a quadrilateral also has to have right angles.
- 4) A square with a side length of 9 cm has an area of 81 square cm.

5) Square roots with a calculator

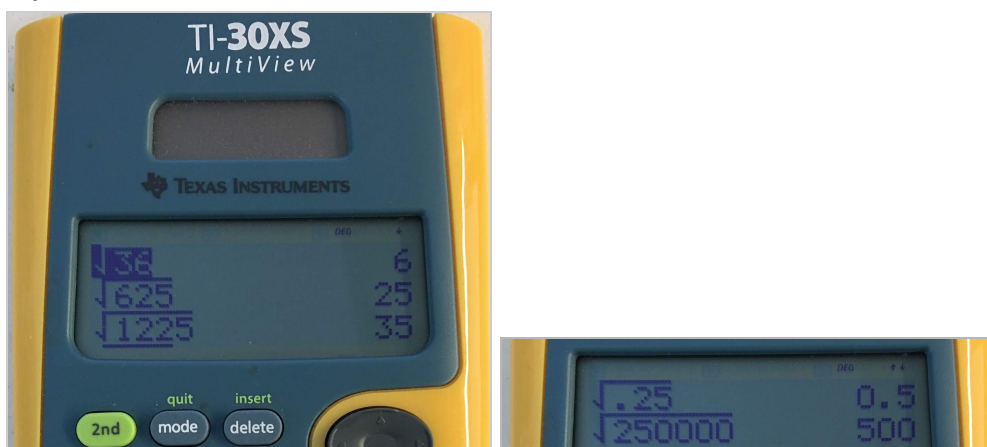

6) Completed chart

Length of one side of the square	The side squared	Area of the square
2	2^2	4
3	3^2	9
4	4^2	16
5	5^2	25
6	6^2	36
7	7^2	49
8	8^2	64
9	9^2	81
10	10^2	100
11	11^2	121
12	12^2	144
13	13^2	169
14	14^2	196
15	15^2	225
16	16^2	256
17	17^2	289
18	18^2	324
19	19^2	361
20	20^2	400

7) Finding square roots

- a) The square root of 576 is **24**.
- b) If the area of a square is 625, the length of one side of the square is **25**.
- c) What number times itself is 729? **27**
- d) $30 \times 30 = 900$.
- e) The square root of 1024 is **32**.

8) How many different polygons can you find in the image below?

There are many, many polygons hidden in the photo of a barn door. Here are a few:

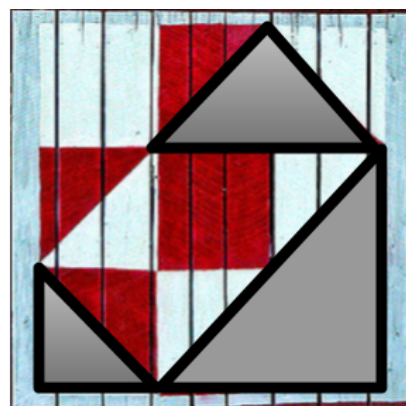
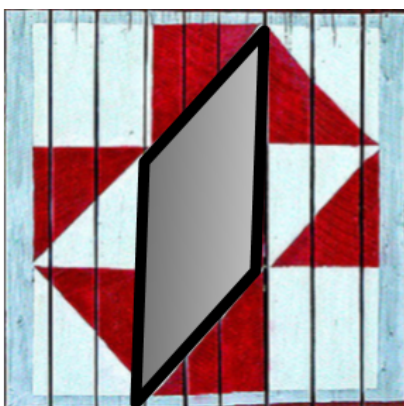

Parallelograms

Triangles

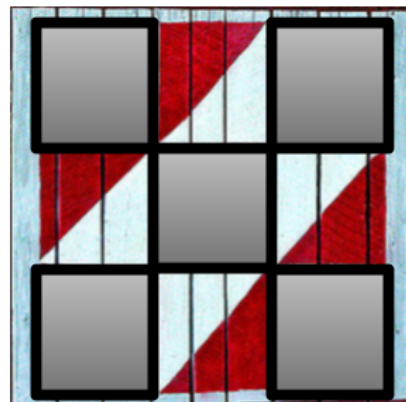
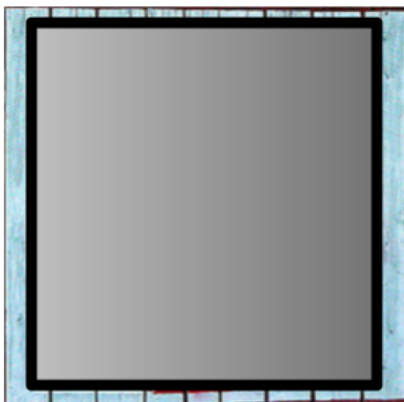

Rectangles

Squares

Triangles

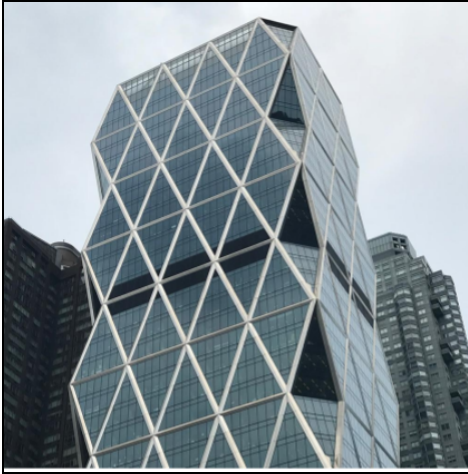

Triangles are polygons with three sides that form three angles.

We often see triangles in structures like bridges and high-rise buildings. Triangles in construction provide strength and stability.

- 1) How many triangles can you find in this picture? (Hint: There are more than 5.)

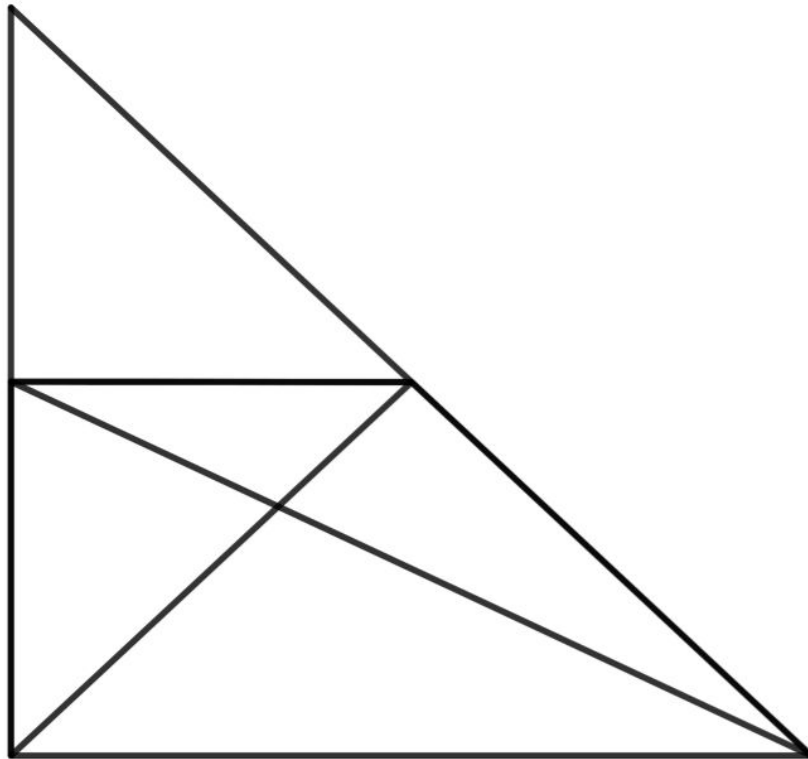

Right Triangles

Right triangles are one of the most important concepts in all of mathematics. Use the examples below to complete a definition for a right triangle.

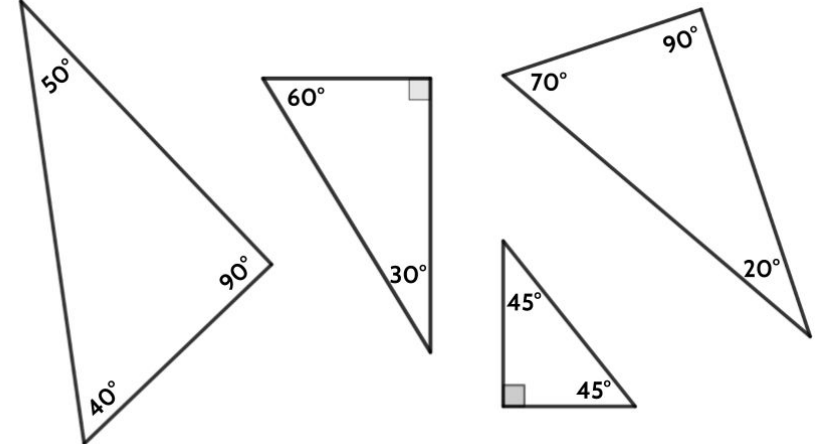
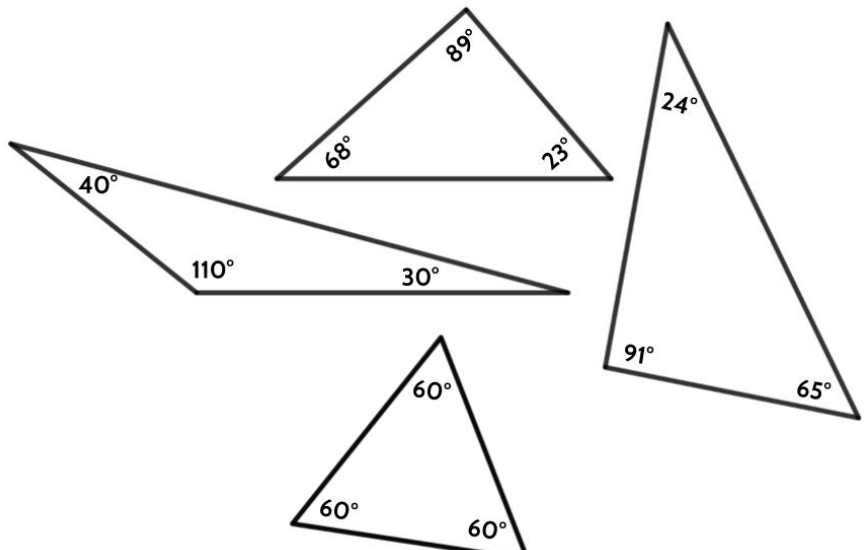
	<p>These are examples of right triangles.</p>
	<p>These are examples of triangles that are <u>not</u> right triangles.</p>

2) A right triangle is a triangle that _____

A right triangle is any triangle that has a 90 degree angle in it.

Note: When you see a little square inside an angle like this: , it means that the angle is 90 degrees. This is the degree symbol: $^{\circ}$. It is used for degrees in an angle and degrees in temperature. For example, you can write 45° to mean a 45 degree angle and you can also write 45° to refer to temperature (a chilly day in Fahrenheit and a really hot day in Celsius).

In a right triangle, we call the two sides that form the right angle, *legs*. We call the side opposite the right angle, the *hypotenuse*. The hypotenuse is always the longest side of a right triangle.

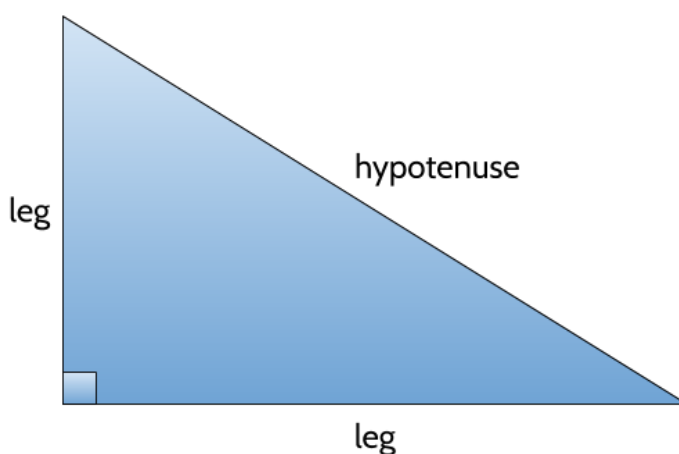

We have special words for the sides of a right triangle because there is a special relationship between those sides. One way to see this relationship is by drawing squares connected to each side of the right triangle.

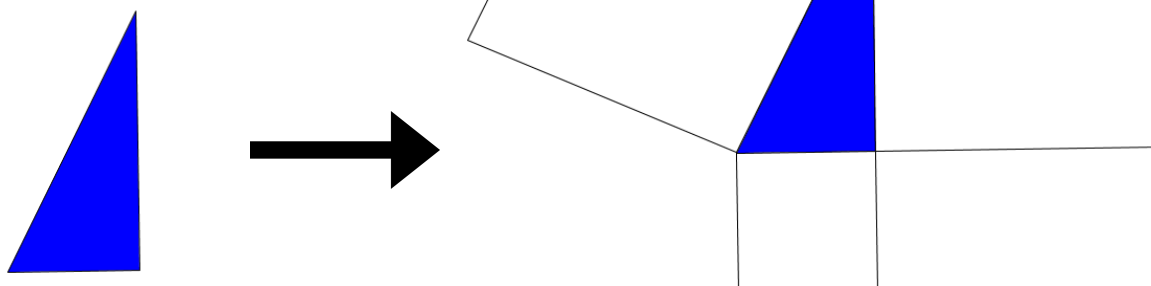

The Pythagorean Theorem

Do you see the triangles inside the squares below? Both are right triangles. There is a square built off the sides of each right triangle.

3) Find the area of each square.

After you find the area of each square: Think about the relationship between the areas of the three squares connected to each triangle. What do you notice?

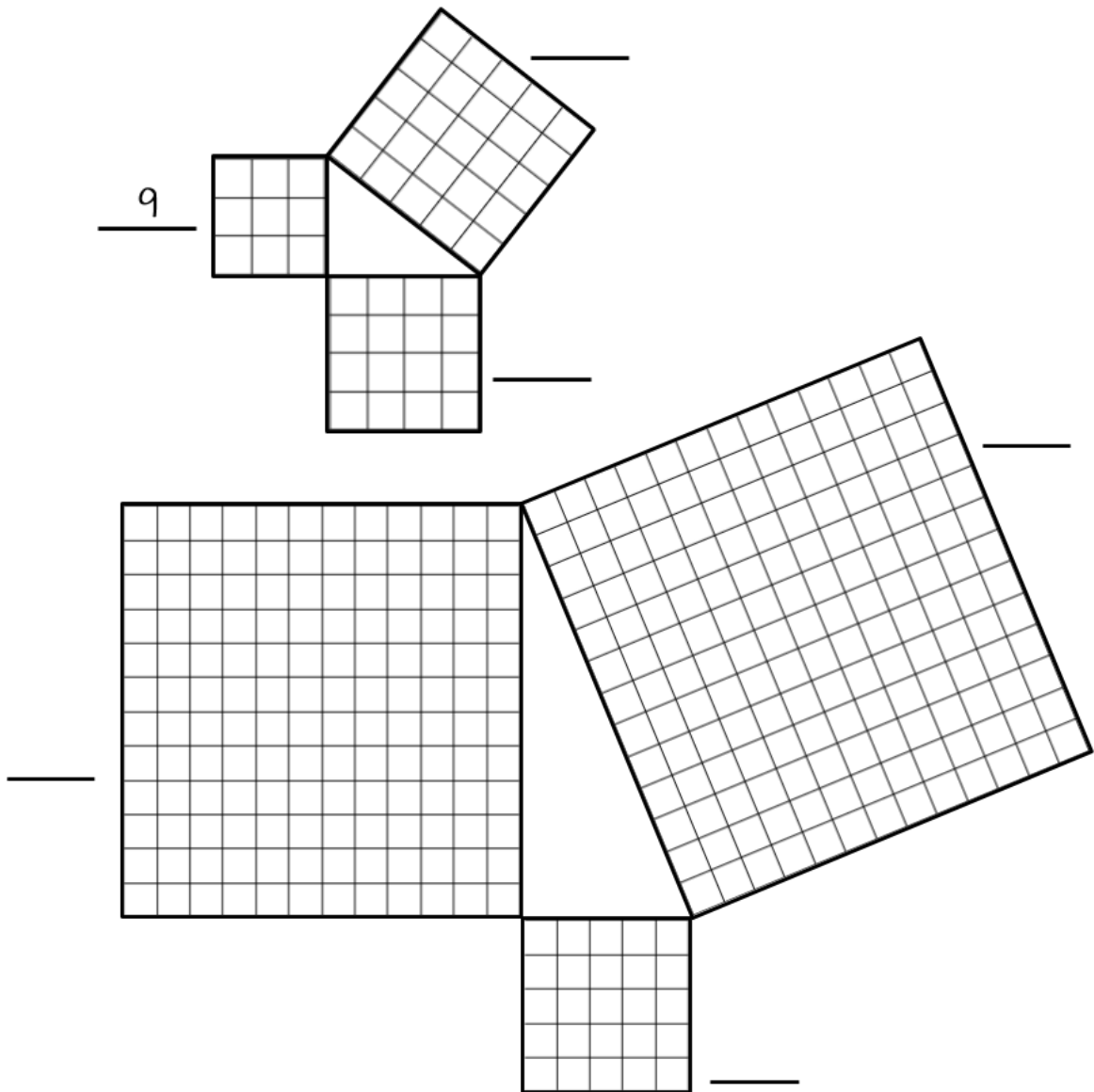

The Pythagorean Theorem:

In a right triangle, the combined areas of the squares built off the legs are equal to the area of the square built off the hypotenuse.

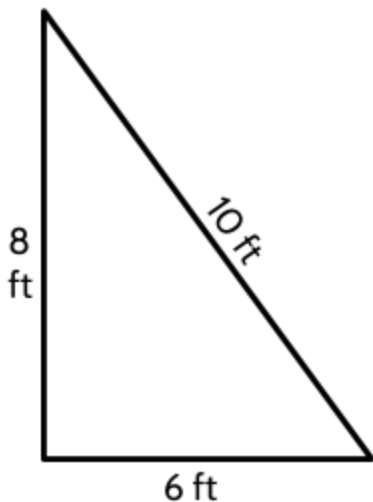

Let's see what happens when we build squares off the sides of a right triangle with legs of 6 feet and 8 feet and a hypotenuse of 10 feet.

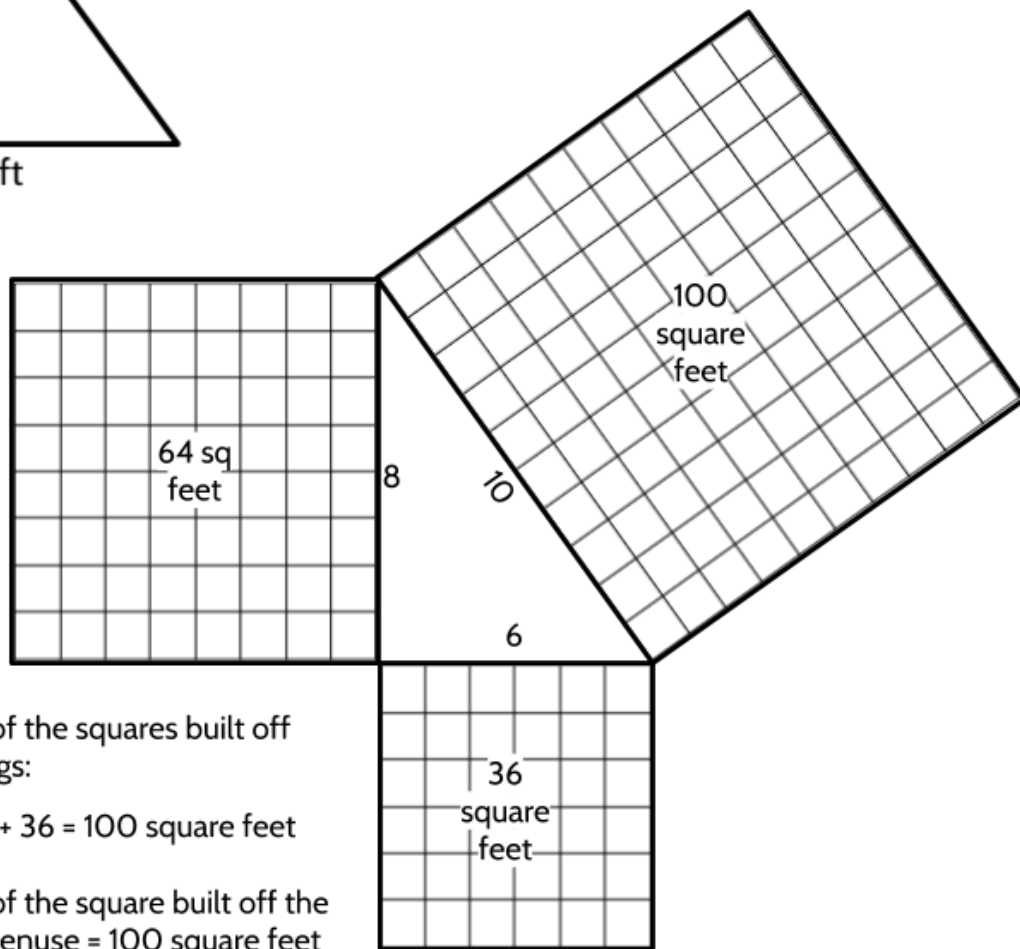

Area of the squares built off the legs:

$$64 + 36 = 100 \text{ square feet}$$

Area of the square built off the hypotenuse = 100 square feet

People recognized this relationship (that the combined squares of the legs of a right triangle are equal to the square of the hypotenuse) thousands of years ago and have been using it ever since. The ancient Egyptians used it in construction over 4500 years ago and without it they could not have built the pyramids. There are several ancient Babylonian stone tablets that are 4000 years old that describe the same relationship. In China, it is called the GouGu Theorem, named for the *Gou* (the shorter leg of the right triangle) and the *Gu* (the longer leg of a right triangle) and was first written about 2000 years ago.

The most common name for the relationship today is the Pythagorean Theorem, named for Pythagoras, a Greek philosopher who was born about 2600 years ago. Many people argue that Pythagoras was not the first person to discover the relationship. Many cultures, especially those in North Africa, the Middle East and Asia were able to use the relationship earlier but it is said that Pythagoras was one of the first people to prove that the relationship is true for any right triangle.

There are two kinds of measurements we can do with the Pythagorean Theorem.

- If we know the lengths of any two sides of a right triangle, we can use this relationship to find the missing length. In this way, the Pythagorean theorem can be used to determine distance.

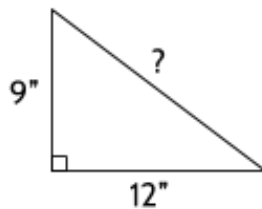

- We can also use this relationship to determine if a triangle is a right triangle. If we know the lengths of the three sides of a triangle, we can use the relationship to test whether the triangle has a 90 degree angle. If the combined areas of the squares built off the legs is equal to the area of the square built off the hypotenuse, then the triangle must have a 90 degree angle.

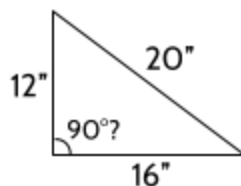

- 4) Larry and Joe Haun, both contractors, have a series of YouTube videos on how to build a house. In the photos below, they are using the Pythagorean Theorem to make sure the corners of a house's foundation are right angles (90°).



Here we can see the brothers using two tape measures to create the legs of a right triangle.



Now, they are measuring the hypotenuse. If they were successful in building a right angle in the foundation, what should the length of the hypotenuse be?



One of the brothers is measuring a length of 6 feet and the other brother is measuring a length of 8 feet.

5) In the diagram below, the area of the smallest square is 81 square feet and the area of the middle-sized square is 144 square feet.

a. What is the area of the largest square?

b. What is the length of the hypotenuse?

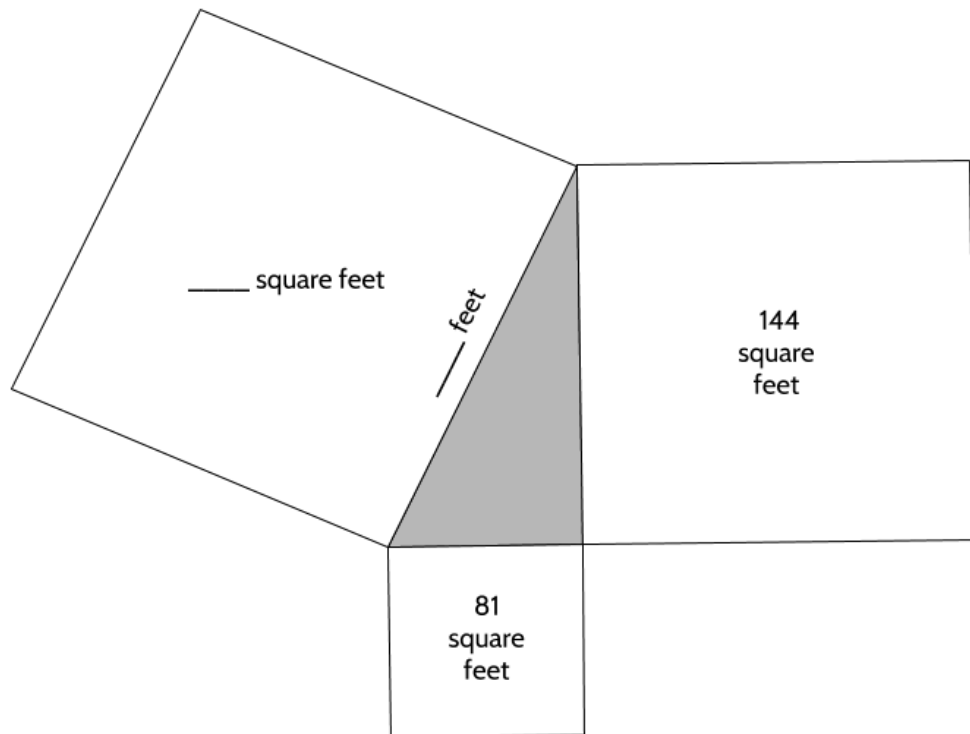

- 6) In the diagram, the length of the shorter leg is 12 feet and the length of the longer leg is 16 feet.
- a) What is the area of the smallest square?
 - b) What is the area of the middle-sized square?
 - c) What is the area of the largest square?
 - d) What is the length of the hypotenuse?

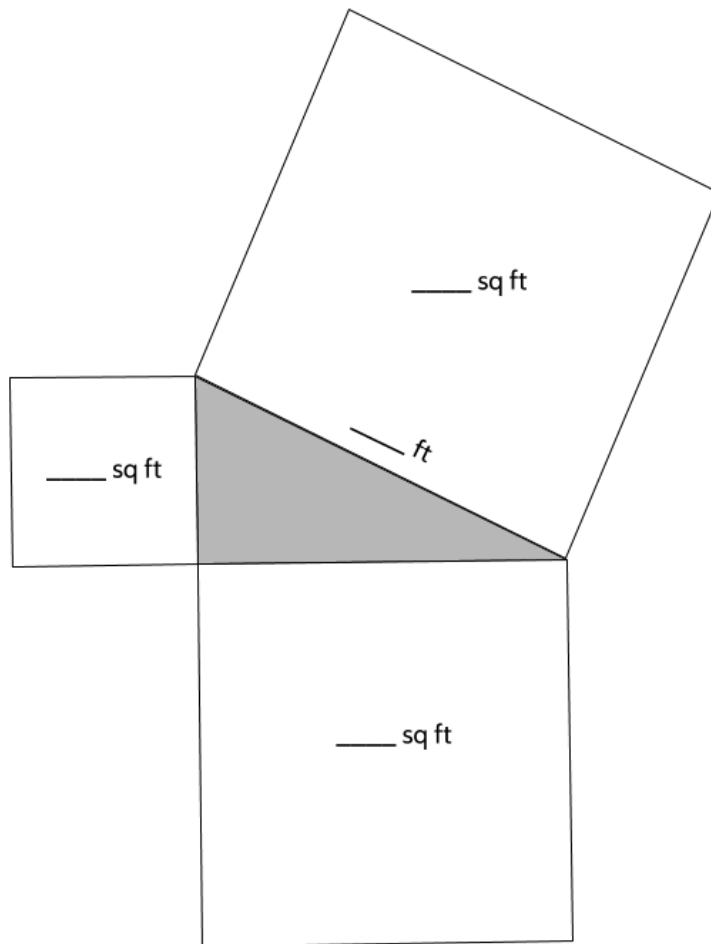

- 7) In the diagram, one side of the smallest square is 3 feet. The area of the middle-sized square is 16 square feet.
- a) Find the area of the smallest square.
 - b) Find length a .
 - c) Find the area of the largest square.
 - d) Find length b .

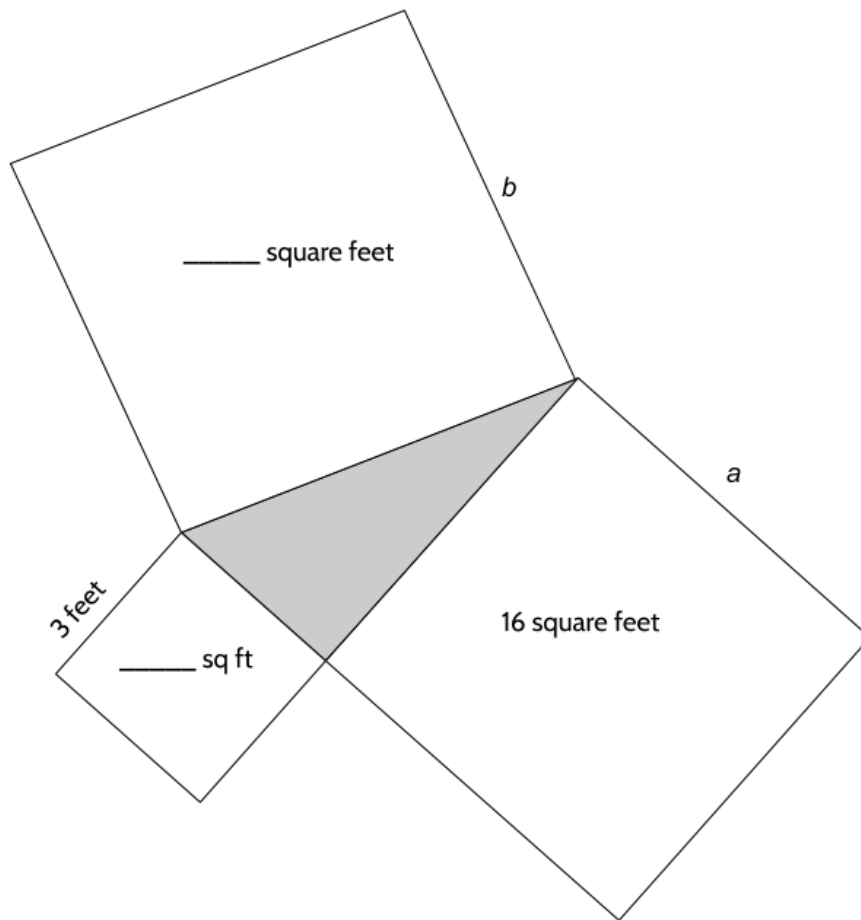

- 8) Sketch squares off each side of the triangle below and use their areas to find length c .

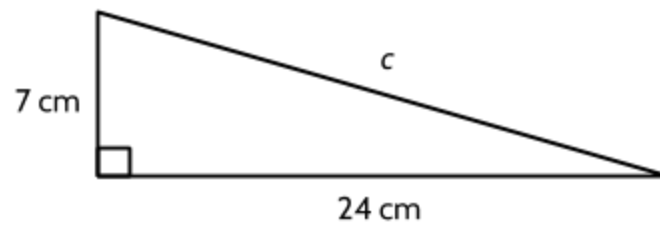

9) Side $b =$ _____ miles

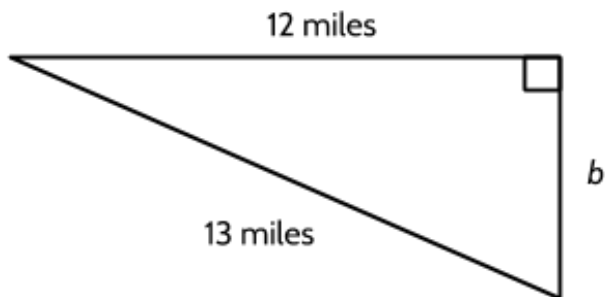

10) Which of the following choices could not represent the side lengths of a right triangle?

- A. 6 feet, 9 feet, and 12 feet
 - B. 6 feet, 8 feet, and 10 feet
 - C. 8 feet, 15 feet, and 17 feet
 - D. 18 feet, 24 feet, and 30 feet
- 11) This 12 feet by 25 feet rectangle has been divided into triangles. Is the shaded triangle a right triangle? Explain your answer.

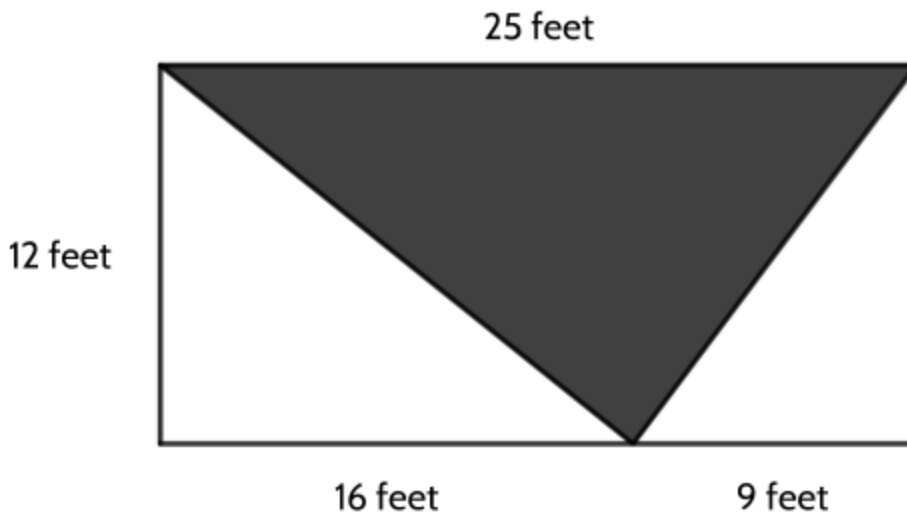

The Pythagorean Theorem states:

In a right triangle, the combined areas of the squares built off the legs is equal to the area of the square built off the hypotenuse.

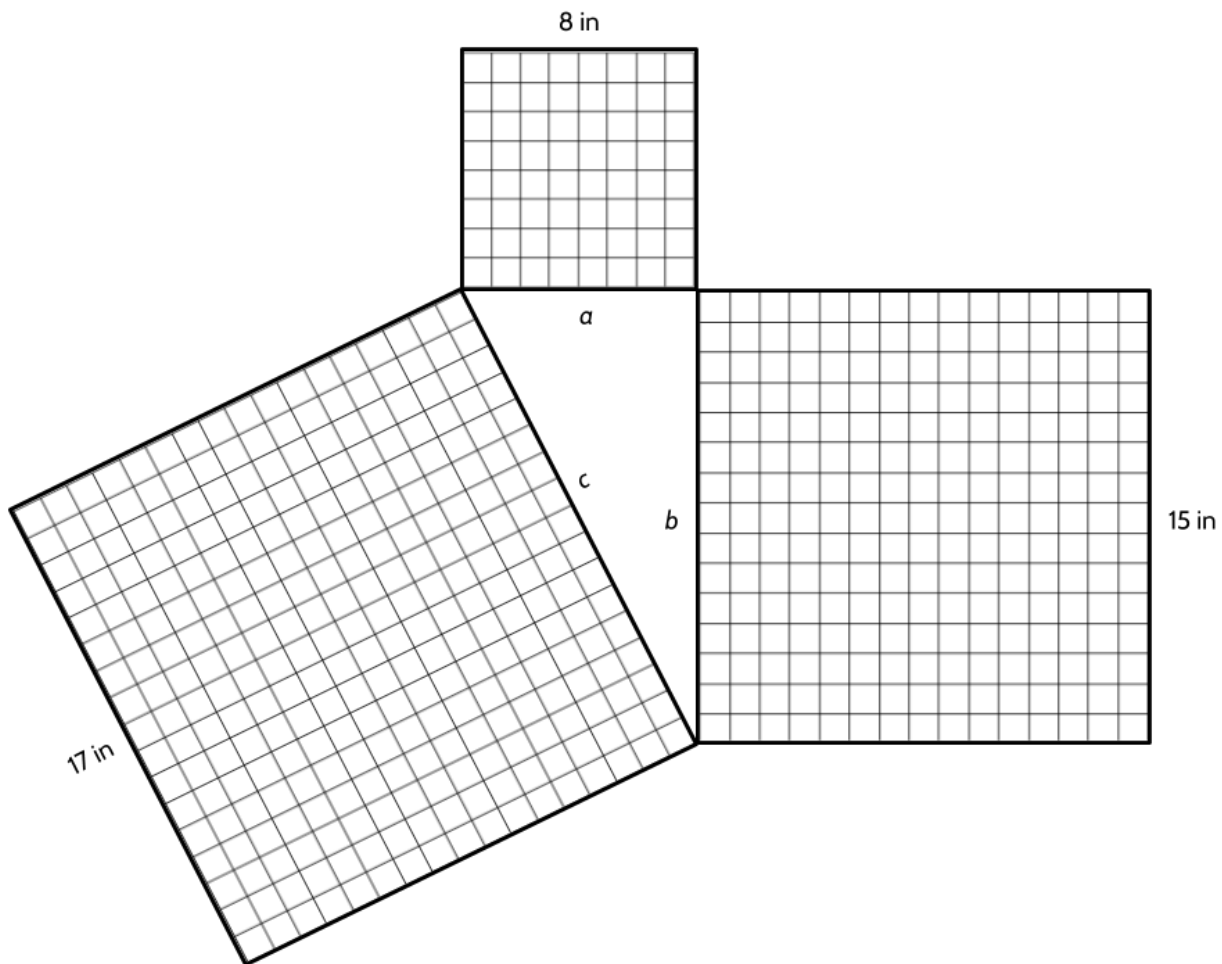

Area of smallest square		Area of middle-sized square		Area of largest square
64	+	225	=	289
8^2	+	15^2	=	17^2
Leg^2	+	Leg^2	=	Hypotenuse^2
a^2	+	b^2	=	c^2

Triangles - Answer Key

1) There are 12 triangles in this picture.

- 1
- 2
- 3
- 4
- 5
- 2 & 5 together
- 2 & 3 together
- 4 & 5 together
- 3 & 4 together
- 1, 2, & 3 together
- 1, 3, & 4 together
- 1, 2, 3, 4, & 5 together

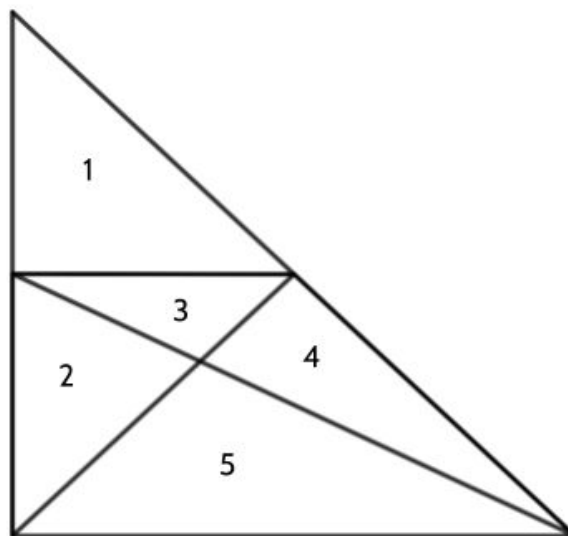

2) A right triangle is any triangle that has a 90 degree angle in it.

3) Areas: 9, 16, 25 and 25, 144, 169.

Did you notice that the area of two smaller squares adds up to the area of the large square? $9 + 16 = 25$ and $25 + 144 = 169$

4) The brothers made legs that were 6 feet and 8 feet in length. If we imagine a square built off those legs would have areas of 36 square feet and 64 square feet. That means the area of the square built off the hypotenuse would be 100 square feet ($36 + 64 = 100$). The side length of a square with an area of 100 square feet would be 10 feet. If their measure of the hypotenuse is 10 feet, then the corner of their foundation is a right angle. Using a right triangle with side measures of 6, 8, and 10 or of 3, 4, and 5 are commonly used in construction to make sure that corners are 90° .

5)

- a) 225 square feet
- b) 15 feet

6)

- a) 144 square feet
- b) 256 square feet
- c) 400 square feet
- d) 20 feet

7)

- a) 9 square feet
- b) 4 feet
- c) 25 square feet
- d) 5 feet

8) Length c is 25 cm.

- 9) Side b is 5 miles, Did you notice that this problem is different from the others you have done so far. For this problem, we are given the hypotenuse and one of the legs. If we build a square off the hypotenuse, it's area would be 169 square miles. If we build a square off the given leg, the area is 144 square miles. We know the sum of the areas of the squares built off both legs will give us the area of the square built off the hypotenuse. We would need to add 25 square miles to 144 square miles to match the area of the largest square. A square that is 25 square miles has a side that is 5 miles in length.
- 10) Choice A. We know the hypotenuse is the longest side of every right triangle. If we square 6 feet and 9 feet, we get 36 sq ft and 81 sq ft which combine to 117 square feet. Since the square built off a length of 12 feet would be 144 square feet, we know this combination of side lengths cannot be a right triangle.
- 11) The shaded triangle is a right triangle. The legs of the shaded triangle are made up of the hypotenuses the two unshaded triangles.

Starting with the triangle on the left: If we build a square off of the side that is 12 feet, we get a square with an area of 144 square feet. If we build a square off the side that is 16 feet, we get a square that has an area of 256 square feet. 144 square feet plus 256 square feet means the square built off the hypotenuse will be 400 square feet. A square that has an area of 400 square feet will have sides that are 20 feet in length. So the hypotenuse of the unshaded triangle on the left is 20 feet.

Working with the unshaded triangle on the right: If we build a square off of the side that is 12 feet, we get a square with an area of 144 square feet. If we build a square off the side that is 9 feet, we get a square that has an area of 81 square feet. 144 square feet plus 81 square feet means the square built off the hypotenuse will be 225 square feet. A square that has an area of 225 square feet will have sides that are 15 feet in length. So the hypotenuse of the unshaded triangle on the right is 15 feet.

That means the legs of the shaded triangle are 20 feet and 15 feet. The square built off the 20 feet side has an area of 400 sq feet. The square built off the 15 feet side has an area of 225 sq feet. That means the area of the square built off of the hypotenuse would have to be 625 square feet ($400 + 225$). If we build a square off of a hypotenuse that is 25 feet, we would get an area of 625 square feet.

Scale, Dilation, and Similarity



In the Queens Museum in New York City, there is an exhibit that has been on display since the 1964 World's Fair. It is called the Panorama of the City of New York. It is a *scale* model of the entire city where one inch in the model equals 100 feet in real life. For example, in real life, the Empire State Building is 1500 feet tall. The model of the Empire State Building in the Panorama is 15 inches tall.

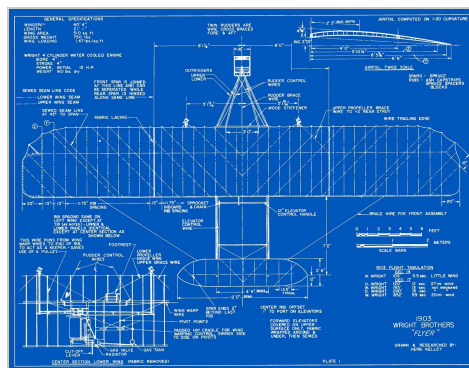

We use scale when we draw or create a model of an object that is larger or smaller than the actual object. Either that is a giant cat or that is a scale model of a 1974 Ford Capri!

Models, maps, and blueprints all use scale. Scale allows us to practice, plan, and study things.

But what does it mean to draw something to scale?

Let's say I want to enlarge this photograph of Pittsburgh Pirate legend Roberto Clemente, tipping his cap to the crowd after collecting his 3,000th hit in 1972.

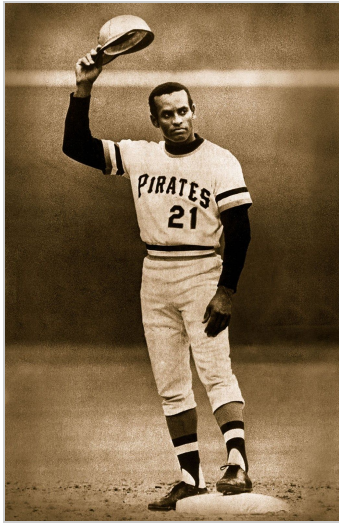

Look at the enlargements on the next page. Which one do you think is the best enlargement?

Explain why you think so.

Which of these is enlarged correctly?

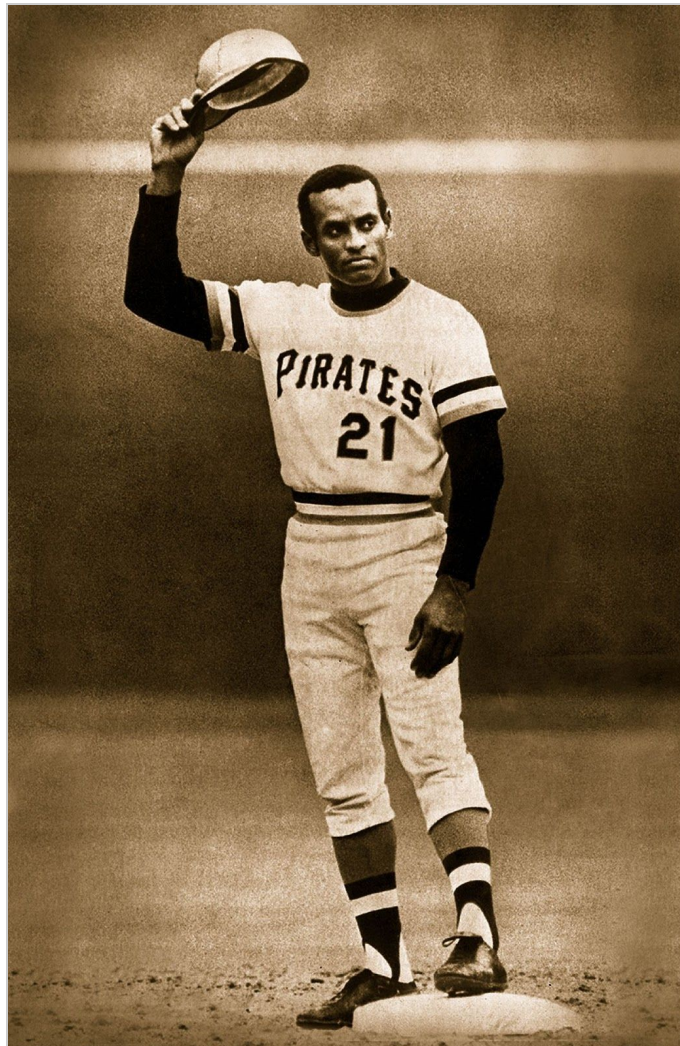

When we enlarge or shrink photographs, we don't want them to look stretched. Below is a correct enlargement of the photograph of Roberto Clemente.

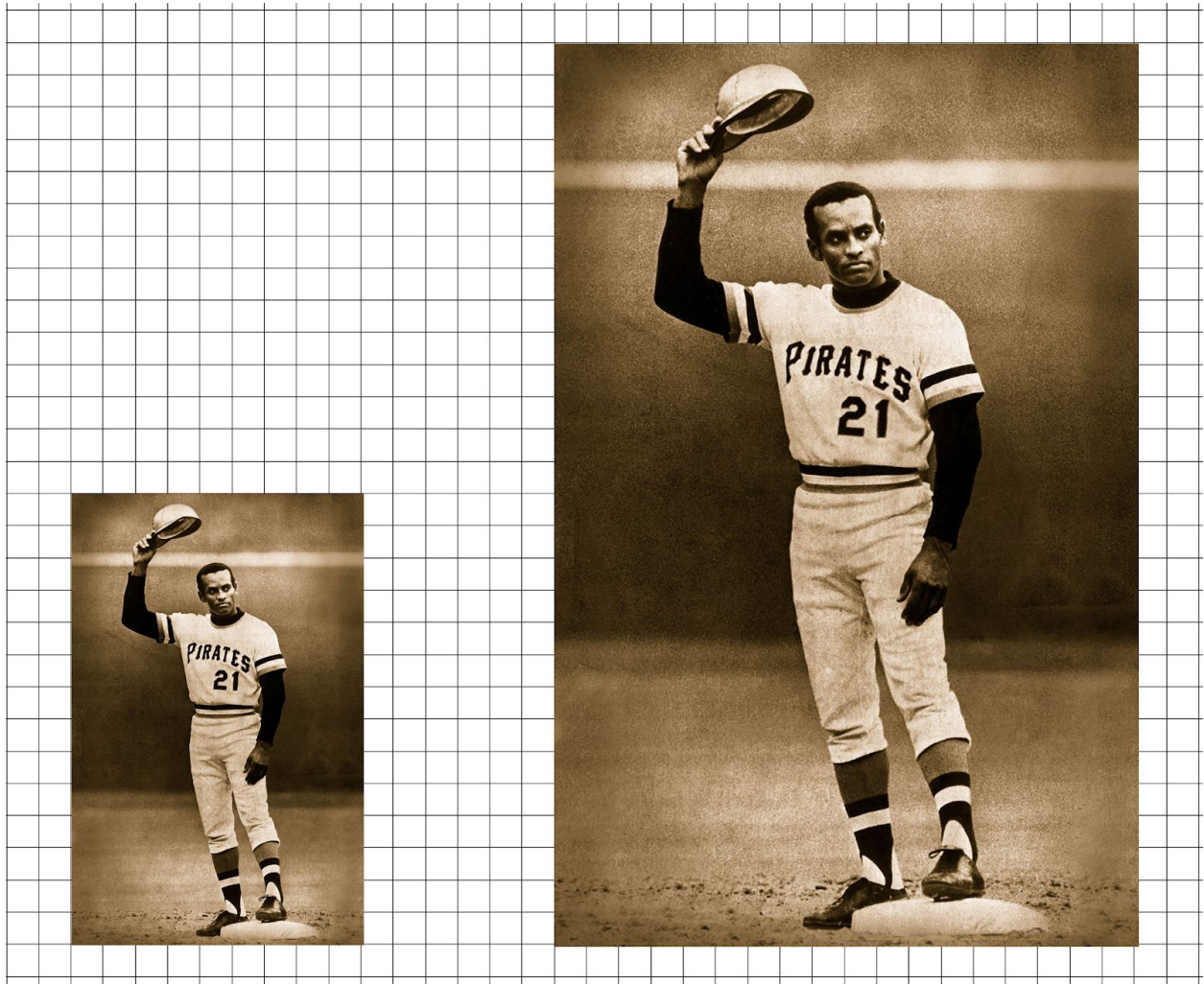

Complete the following sentence:

When I use the grid, I notice that the photograph on the right is...

One thing you may have noticed is that the smaller photograph is 9 boxes wide and 14 boxes tall. The bigger photograph 18 boxes wide and 28 boxes tall.

We can say that these images are dilations of each other. A *dilation* makes a figure larger or smaller without changing its shape. Dilations can be described by the term *scale factor*.

For example, the image of Roberto Clemente on the right is two times larger than the image on the left. We can say that the larger image is a dilation of the smaller image by a scale factor of 2. That means that it is two times larger.

We can also say that the smaller image is a dilation of the larger image by a scale factor of $\frac{1}{2}$. That means it is half the size as the larger image.

If we look at the dilations as simple rectangles, we can say that the two rectangles are mathematically similar. **Similar** figures are the same shape, but they are different sizes. You can enlarge or shrink the figure so that it is large or small enough to cover the other figure.

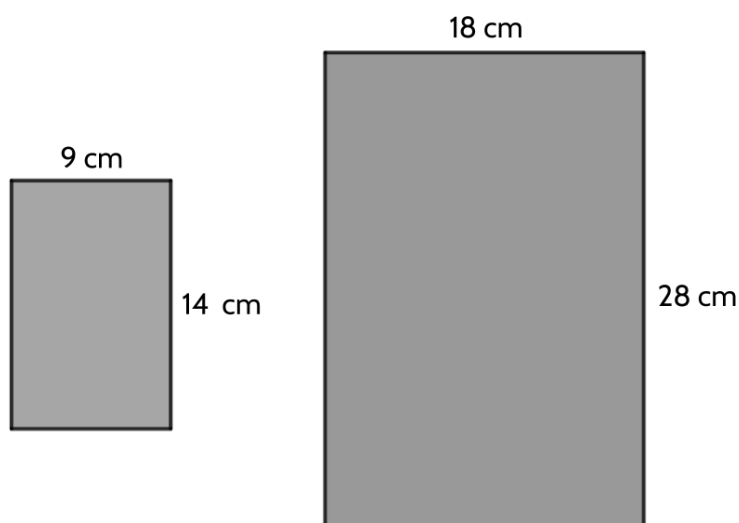

Notice how each length is related to the corresponding length in the dilated image.

To go from the rectangle on the left to the rectangle on the right, the scale factor is 2.

18 is two times bigger than 9. 28 is two times bigger than 14.

Each pair of corresponding sides has the same scale factor.

Rectangle ABCD and Rectangle LMNO are similar.

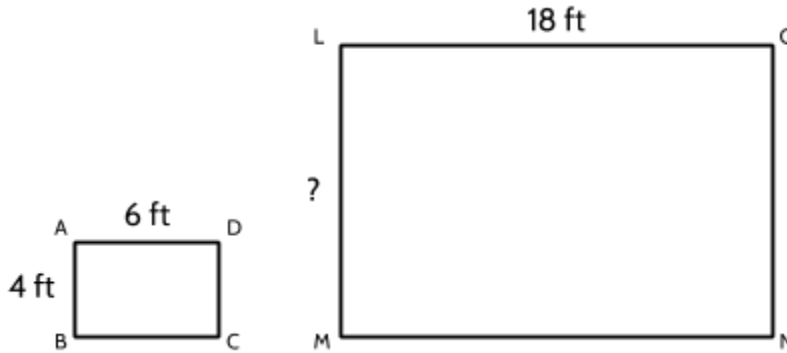

- 1) Which sides in Rectangle ABCD correspond to which sides in Rectangle LMNO? How do you know?
- 2) What is the scale factor to go from Rectangle ABCD to Rectangle LMNO? How do you know?
- 3) What is the length of \overline{LM} ? How do you know?
- 4) What is the perimeter of each rectangle? What is the area of each rectangle?

Rectangle ABCD
Perimeter = _____
Area = _____

Rectangle LMNO
Perimeter = _____
Area = _____

5) Which rectangles are similar?

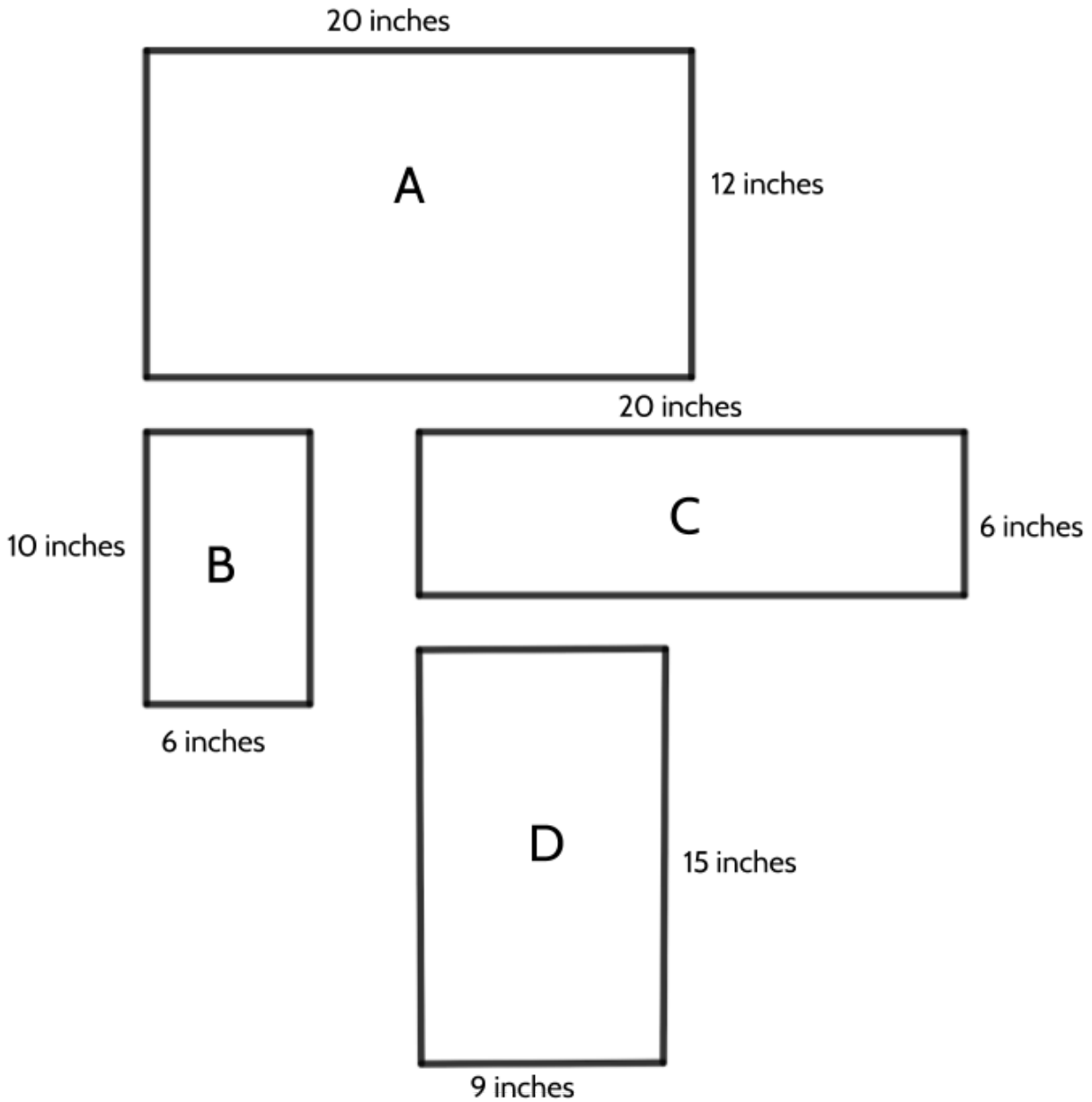

- 6) Using the digits 0-9, at most one time each, fill in the boxes so that one rectangle is a scaled drawing of the other.¹

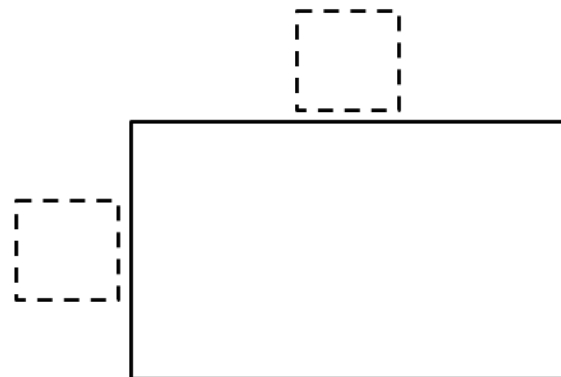
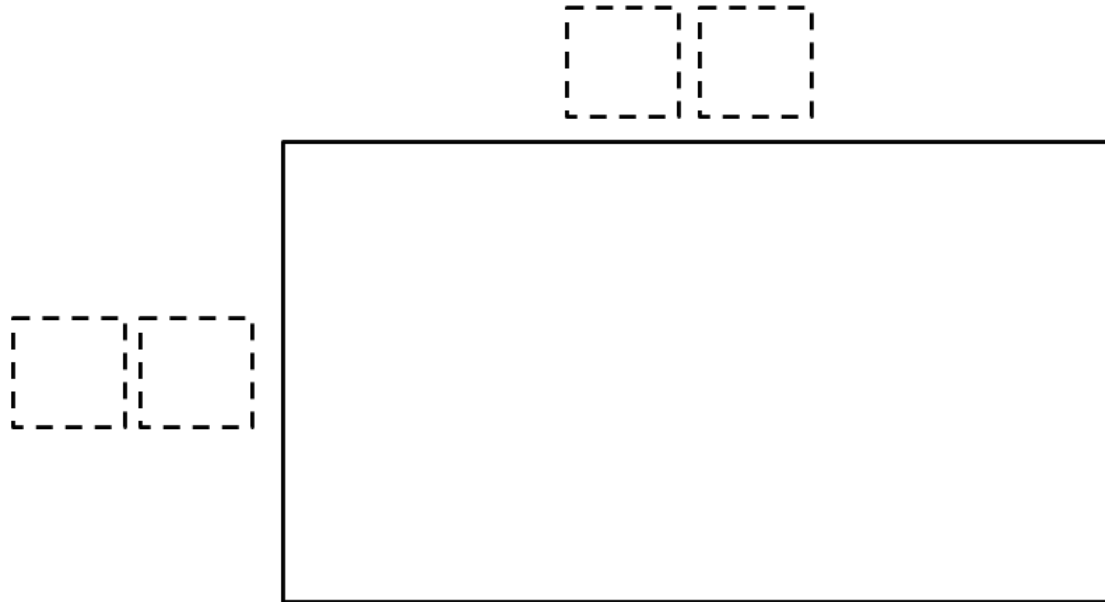

¹ Inspired by an activity from Open Middle - openmiddle.com

Similarity within Triangles

The same ideas of scale, dilation, and similarity apply to other shapes as well.

Here are four similar right triangles.

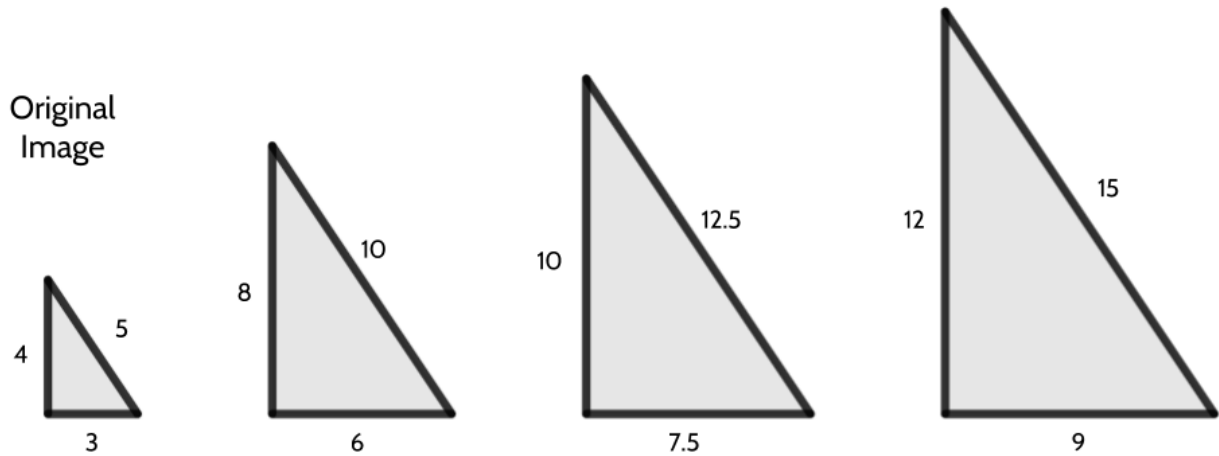

Write 5 things you notice about these shapes.

One thing you may have noticed is that these are all right triangles. The original image is a 3-4-5 right triangle. Since dilation only changes the size and not the shape of a figure, the enlargements are also all right triangles.

But don't take our word for it—choose one of the enlarged triangles and use the Pythagorean Theorem to test whether it is still a right triangle.

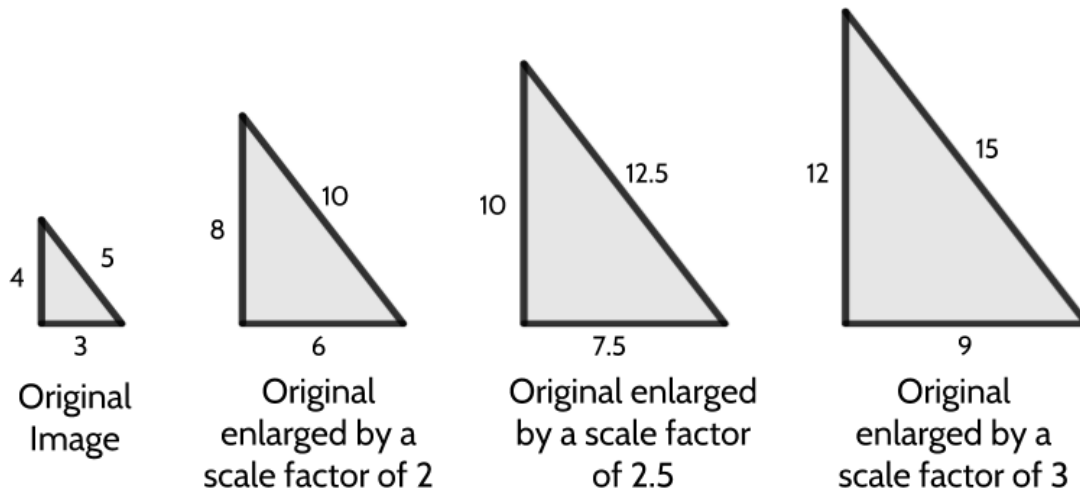

The largest triangle in this diagram is a dilation of the original image by a scale factor of 3. To go from the original image to this triangle, we multiply the length of each side by 3.

$$3 * 3 = 9$$

$$4 * 3 = 12$$

$$5 * 3 = 15$$

What if we needed to reduce the 9-12-15 triangle? What scale factor could we use to reduce the largest triangle back to the size of the original image?

When two shapes are similar, if we divide the lengths of the larger shape by the scale factor, we get the lengths of the smaller shape.

$$9 \div 3 = 3$$

$$12 \div 3 = 4$$

$$15 \div 3 = 5$$

And if we need to figure out the scale factor?

In the diagram below $\triangle QRS$ and $\triangle ABC$ are similar. We have all of the corresponding lengths of each triangle. What is the scale factor?

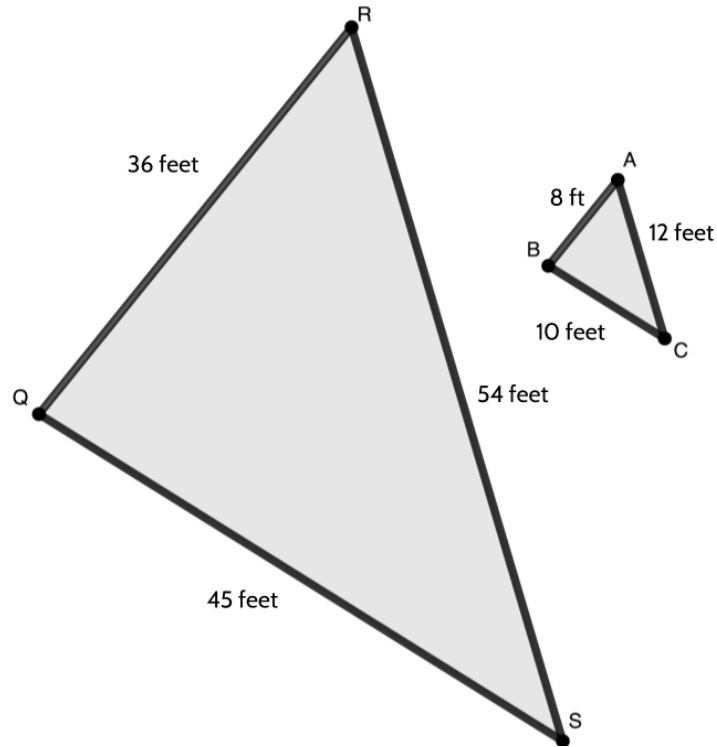

One question that can help is, “How many of the smaller lengths fit in each corresponding larger length?”

For example, how many 8 foot sections are there in 36 feet? How many 10s are there in 45? How many 12s are there in 54?

We can use division to answer that question.

If we divide 36 by 8, we can see how many 8’s fit in 36. $36 \text{ feet} \div 8 \text{ feet} = 4.5$

Since the triangles are similar, that same scale factor must describe the relationship between all the corresponding lengths.

$$12 \text{ feet} \times 4.5 = 54 \text{ feet}$$

$$10 \text{ feet} \times 4.5 = 45 \text{ feet}$$

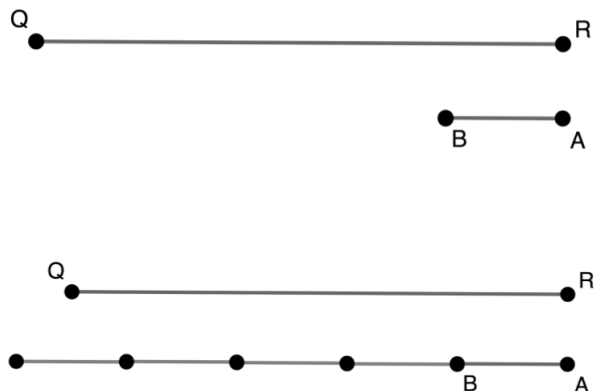

7) Complete this chart of lengths from dilated right triangles.

In the final row, choose your own dilation and scale factor (enlarge/reduce).

	Corresponding Sides		
Original	3	4	5
Enlarged by scale factor of 2	6	8	10
Enlarged by scale factor of 2.5	7.5	10	12.5
Enlarged by scale factor of 3	9	12	15
Enlarged by scale factor of 4			
Enlarged by scale factor of 5			
Enlarged by scale factor of _____	30	40	50
Enlarged by scale factor of _____	45	60	75
Reduced by a scale factor of $\frac{1}{2}$			

Understanding dilation allows us to solve different kinds of problems. You solved two kinds in the chart above.

On the high school equivalency test, you might be given the lengths of a shape and the scale factor and asked to figure out the lengths of the new dilated figure.

You might also be given the lengths of an original image and a dilated image and be asked to figure out the scale factor.

A third kind of problem might require you to figure out the scale factor between two similar shapes and then use it to figure out one of the lengths.

Questions 8-10 fit into the third category.

8) The two triangles below are similar triangles.

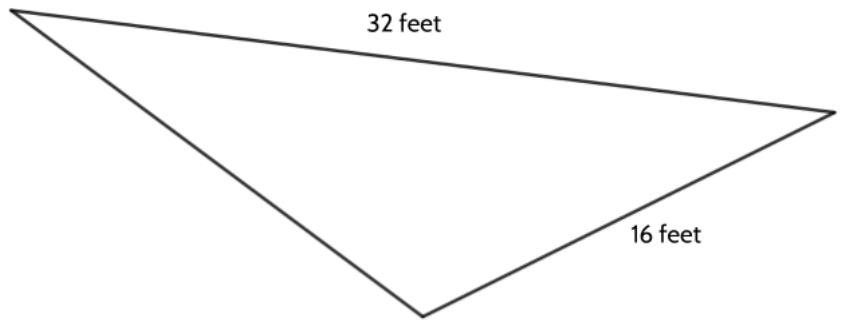
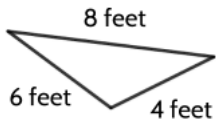

What is the perimeter of the larger triangle?

Sometimes similar triangles will overlap each other. The first question to ask yourself is how many triangles there are in the diagram. Do you see the two similar triangles in question 9?

9) What is the length of side x ?

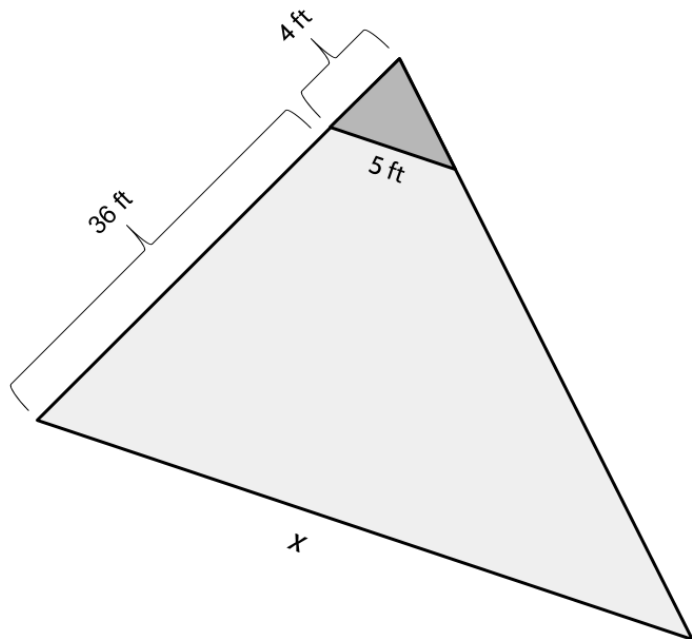

10) The two triangles below are similar. What is the length of x ?

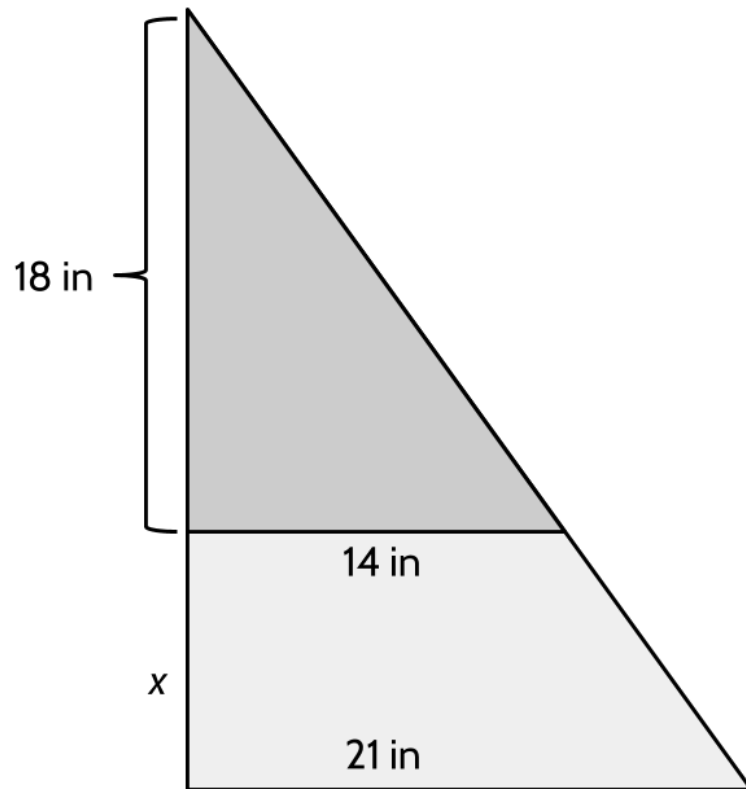

Scale, Dilation, and Similarity - Answer Key

- 1) \overline{AB} corresponds to \overline{LM} . \overline{CD} corresponds to \overline{NO} . \overline{AD} corresponds to \overline{LO} . \overline{BC} corresponds to \overline{MN} .
- 2) Rectangle LMNO is enlarged from Rectangle ABCD by a scale factor of 3. Corresponding sides \overline{AD} and \overline{LO} are 6 and 18. 18 is 3 times larger than 6.
- 3) \overline{LM} is 12 feet. The corresponding side to \overline{LM} is \overline{AB} and the scale factor is 3. Since \overline{AB} has a length of 4 feet, \overline{LM} will be 3 times 4, which is 12.
- 4) The perimeter of Rectangle ABCD is 20 feet. The area is 24 sq ft.
The perimeter of Rectangle LMNO is 60 feet. The area is 216 sq ft.
- 5) Rectangles A and B are similar. They are rotated, but we can still see the relationship between the corresponding sides. The shorter sides in A and B are 12 and 6. The longer sides are 20 and 10. By looking at the relationship between the corresponding sides, we can see that Rectangle B is dilated by a scale factor of 2 to give us Rectangle A.

Did you also notice that Rectangle D is also similar to Rectangles A and B? It is a harder to see, but there are a few ways to think about it.

Rectangle B is 6 inches and 10 inches. Rectangle A is 12 inches and 20 inches. For every 6 inches on the shorter side, the longer side needs to gain 10 inches.

Rectangle D is 9 inches on its shorter side. That is 6 and then half of 6. Rectangle D is 15 inches on its longer side. That is 10 and then half of ten. So Rectangle D is 1 and a half times bigger than Rectangle B.

Another way to think about it is to ask, "How many 6 are there in 9?" If you divide 9 by 6 you get 1.5. Then we can look at the other corresponding sides. If you divide 15 by 10 you also get 1.5. That means both sets of corresponding sides have been enlarged by the same scale factor.

- 6) There are many answers possible. Here are two of them:

The smaller rectangle is 2 by 8. The larger rectangle is 14 by 56. The scale factor would be 7.

The smaller rectangle could be 3 by 8. The larger rectangle could be 15 by 40. The scale factor would be 5.

7)

Original	Corresponding Sides		
	3	4	5
Enlarged by scale factor of 2	6	8	10
Enlarged by scale factor of 2.5	7.5	10	12.5
Enlarged by scale factor of 3	9	12	15
Enlarged by scale factor of 4	12	16	20
Enlarged by scale factor of 5	15	20	25
Enlarged by scale factor of 10	30	40	50
Enlarged by scale factor of 15	45	60	75
Reduced by a scale factor of $\frac{1}{2}$	1.5	2	2.5

- 8) The perimeter of the larger triangle is 72 feet. Since we are told the triangles are similar, we can look at the corresponding sides to find the scale factor. The larger triangle is 4 times larger than the smaller triangle. We can use that information to see that the missing side of the larger rectangle is 24 feet. Its corresponding side in the smaller triangle is the side with a length of 6.

$$32 \text{ feet} + 24 \text{ feet} + 16 \text{ feet} = 72 \text{ feet.}$$

- 9) 50 feet.

There are two triangles here. The smaller triangle on top is similar to the entire triangle. The 36 ft and the 4 ft combine to make the left side of the triangle 40 feet. The corresponding length to that is the side that is 4 ft. From the corresponding lengths of 4 and 40, we know there is a scale factor of 10. Since 5 ft and x are corresponding sides and the scale factor is 10, x would be 50 feet because that is 10 times longer than 5 ft.

- 10) 9 inches.

The base of the triangles are corresponding sides. If we ask ourselves, "How many 14s fit in 21?" we take 21 divided by 14, which gives us a scale factor of 1.5. If the side of the smaller triangle measures 18 inches then its corresponding side would have to be 1.5 times bigger than that, which is 27. Since we already have 18 inches of the 27 inches, the missing length is 9 inches.

Circles

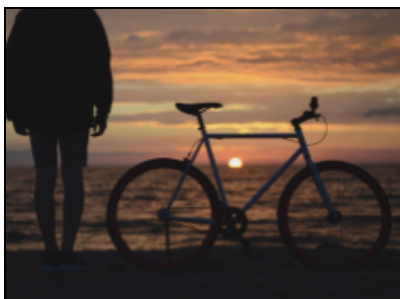

Bicycle wheels at sunset

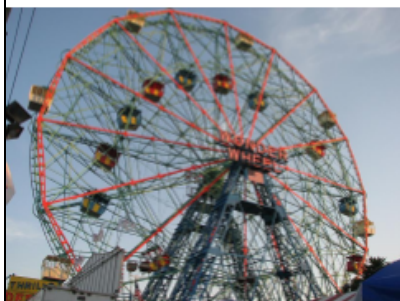

*The Wonder Wheel
Coney Island, NY*



*The water wheel of a mill for
grinding grain into flour*

Humans have a long history with the circle. From the first time we looked up and saw the sun, the circle has captivated our imaginations. Circles are all around us, both in nature and made by humans. We see hundreds of different circles every day. The circle inspired the invention of the wheel, which has revolutionized human experience on Earth.

But what is a circle?

In the space below, draw a perfect circle. (You can try a few times.)

Chances are what you just drew is not a circle. It may be “circular,” meaning shaped *like* a circle, but it is incredibly difficult to draw a perfect circle by hand. What does it even mean to draw a perfect circle?



Tree rings can tell us all kinds of information about every year of a tree's life, but they are not perfect circles.

Let's start with a definition.

A *circle* is the set of all points at a given distance from a center point.

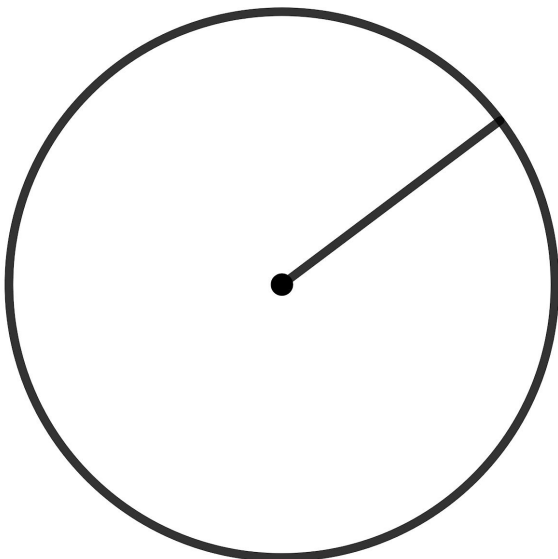

In a perfect circle, any line segment that goes from the center point to the edge of the circle will be the same length. Because it helps us define what a circle is, we give that line segment a special name.

The *radius* of a circle is the line segment from the center point to the edge of the circle. When we are talking about one line segment, we say “radius.” When we are talking about more than one, we say “radii.” Every circle has an infinite number of radii. And each radius inside a circle is equal in length.

Imagine a drip of water creating a ripple in a lake. The place where the drop hits the water is the center of the circle. The ripples form perfect circles because they move away from that center at the same speed and travel the same distance.



Observe the grass in the photo on the left. Its roots keep it in the same spot, creating a center point. When the wind blows, it moves the blades of grass and creates several circles around that center point. In this example, the length of each blade of grass would be the radius of the circle it creates in the sand.

Lines, Shapes, & Angles: Measuring Our World (Part 2)

Thousands of years ago, one of the tools humans used to draw circles was similar to the grass example. They would tie two posts to either end of a piece of rope. They would sink one post into the ground to serve as the center point. Then they would pull the rope tight and walk around the center point, dragging the other post in the sand. By this method, they could draw all the points at the distance they wanted around the center point.

You may have seen a more modern tool, called a *compass*, used to draw a perfect circle.

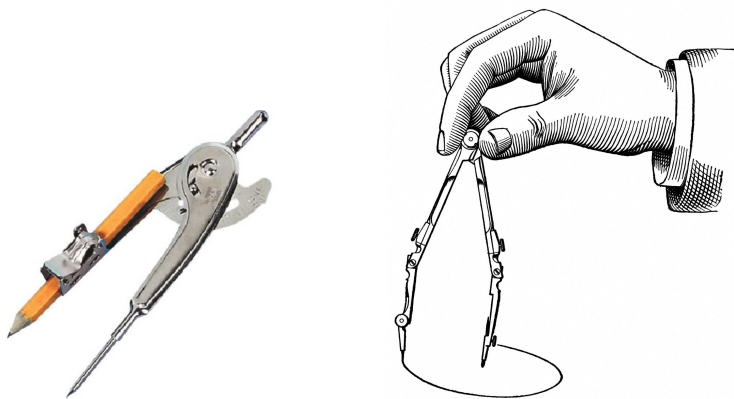

It is not impossible to draw a circle free hand. There is a video on Youtube of math teacher Alexander Overwick, the “world freehand circle drawing champion”, taken by one of his students. In it, Overwick demonstrates his technique. The video has been viewed over 13 million times.

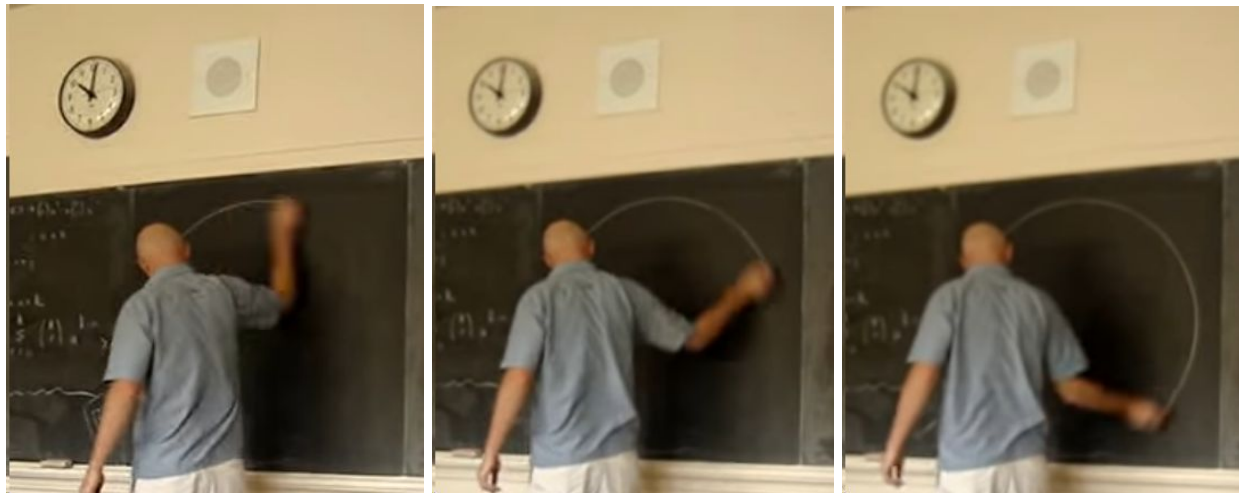

Parts of a Circle

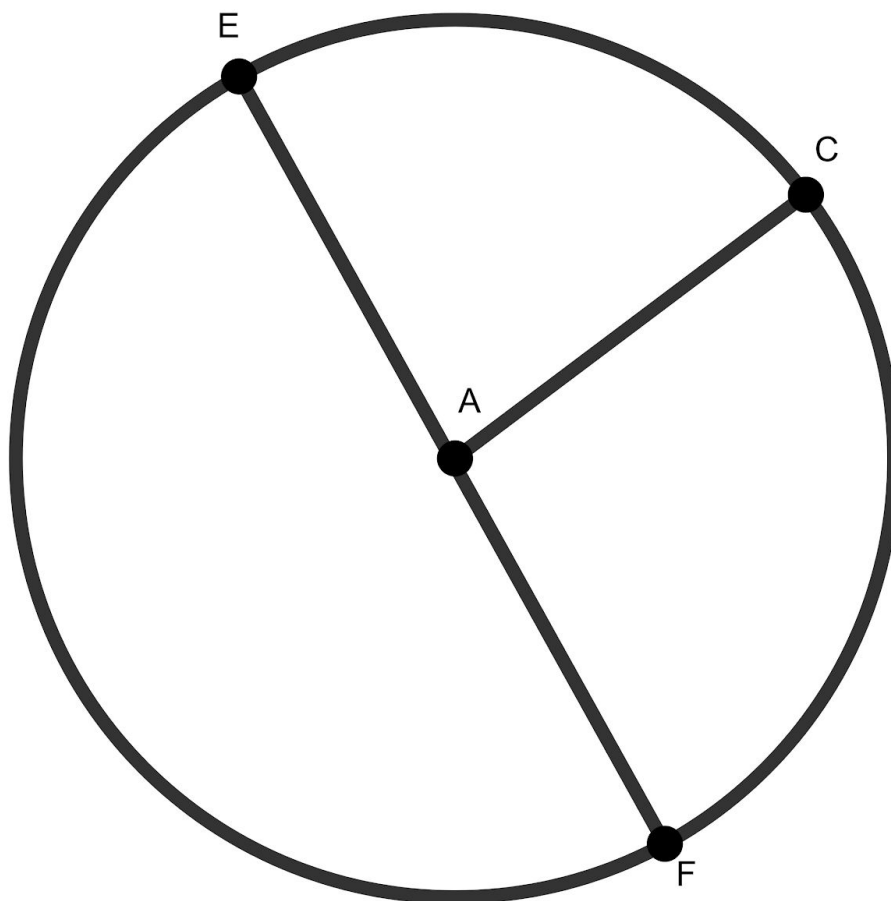

- \overline{AC} is a *radius* of this circle. It is a line segment from the center point (A) to the edge of the circle. \overline{EA} and \overline{AF} are also examples of radii.
- \overline{EF} is a *diameter* of this circle. A *diameter* of a circle is a line segment that goes from one edge of the circle to another, passing through the center point. A diameter is equal to the lengths of 2 radii. Put another way, the diameter is twice as long as a radius. And a radius is half the length of a diameter.
- We have used the word *perimeter* to describe the whole length of a border around a shape. Circles have a special word to describe the distance around the circle. That word is *circumference*.
- We can divide the circumference of a circle into sections. We call each section the *arc* of the circle. Arc EC, Arc CF, and Arc EF are all examples of arcs in this circle.

The Relationship Between the Circumference and the Diameter

The chart below has measurements² for several circular objects of all different sizes.

Circle	Length of the Diameter	Length of the Circumference
A quarter	1 in	3 $\frac{1}{4}$ in
A can of tuna	8 cm	24.5 cm
A plate	10 in	31 in
A vinyl record (LP)	12 in	36 in
A CD	4 $\frac{3}{4}$ in	15 in
A wall clock	33 cm	103 cm
An orange slice	9 $\frac{1}{2}$ cm	29 cm
A frisbee	10 $\frac{1}{8}$ in	34 in
A hula hoop	35 in	112 in
A car tire	25 in	78 in

What do you notice about the relationship between the length of the *diameter* and the length of the *circumference* in each circular object?

² Note that all of these measurements are approximate.

One thing you might have noticed is that for each of these circular objects, whatever the diameter is, the circumference is about 3 times bigger. If you didn't notice, go back and try it with a few of the objects.

In fact, it is true of any circle of any size in the entire universe—the circumference is a little more than 3 times bigger than the diameter.

In fact, because this relationship is true for any circle, including the planet Earth itself, there is a special Greek letter we use to describe it. That letter is *pi*, π , the 16th letter in the Greek alphabet. π is the first letter in the Greek word for “perimeter” and the Greek word for “periphery” (meaning the outside edge of something) and so the Greeks used π as the name for this special relationship.

You may have heard pi described as 3.14. But this is only an estimation of pi to three digits. Using computers, mathematicians have been able to calculate pi to TRILLIONS³ of digits. Pi actually has an infinite number of digits.

The first 30 digits of pi are 3.14159265358979323846264338327... and it keeps going.

Most of the time in our everyday lives, 3.14, or even 3, will be precise enough for our calculations. It's important to remember that pi isn't just a number. In any circle, pi is the number of times larger the circumference is compared to the diameter.

- 1) How could you figure out the diameter across a circular pond that has a circumference of about 558 feet?
- 2) The Wonder Wheel in Coney Island, pictured on the first page of this section, has a diameter of 135 feet. What would you estimate its circumference would be?
- 3) A bicycle wheel has a radius of about 13 inches. How far does the bike travel with every full revolution of the wheel?

³ A trillion is the same as one million million and can be written as a 1 followed by 12 zeros (1,000,000,000,000).

Circles - Answer Key

- 1) The circumference is about 3 times bigger than the diameter. We can divide 558 feet into 3 equal parts and get a diameter of about 186 feet as a rough estimate. If you divide 558 feet by 3.14, you get a more precise measurement of 177.7 feet for the diameter.
- 2) Dividing the circumference of the Wonder Wheel gives an estimate of a little more than 405 feet. Using 3.14 gives a circumference of 423.9 feet.
- 3) Since the radius of the wheel is 13 inches, the diameter of the wheel is 26 inches. Each full revolution of the wheel is a complete length of the circumference of the wheel. The circumference of a bicycle wheel is about 78 inches. If you use 3.14, you get a circumference of 81.64 inches, or almost 7 feet.

Test Practice Questions

Answer the following questions. You can check your answers in [Test Practice Questions - Answer Key](#). These questions will review what you have learned in Part 1 and Part 2 of Lines, Angles, & Shapes.

- 1) s , w , and p represent the sides of the right triangle below.

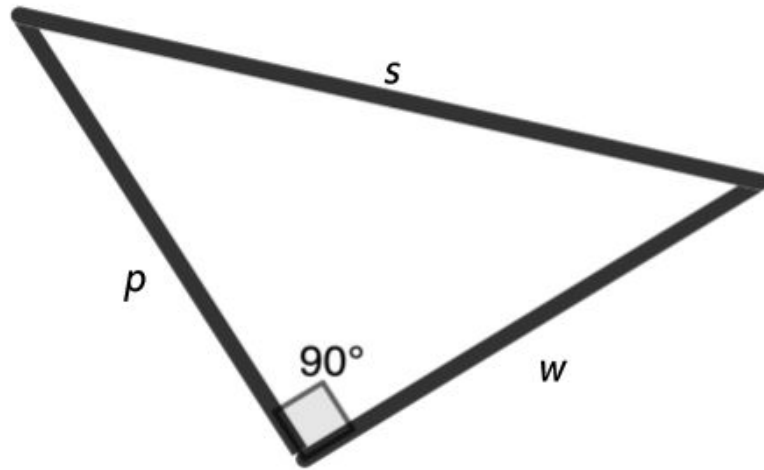

Which of the following statements is not true?

- A. $p^2 + w^2 = s^2$
- B. $s^2 - p^2 = w^2$
- C. $s^2 + p^2 = w^2$
- D. $s^2 - w^2 = p^2$

2) Line segments YX and WZ intersect at Point X.

Which of the following calculations could be done to find the measure of $\angle YXZ$?

- A. $104^\circ - 90^\circ$
- B. $180^\circ - 104^\circ$
- C. $360^\circ - 104^\circ$
- D. $104^\circ + 180^\circ$

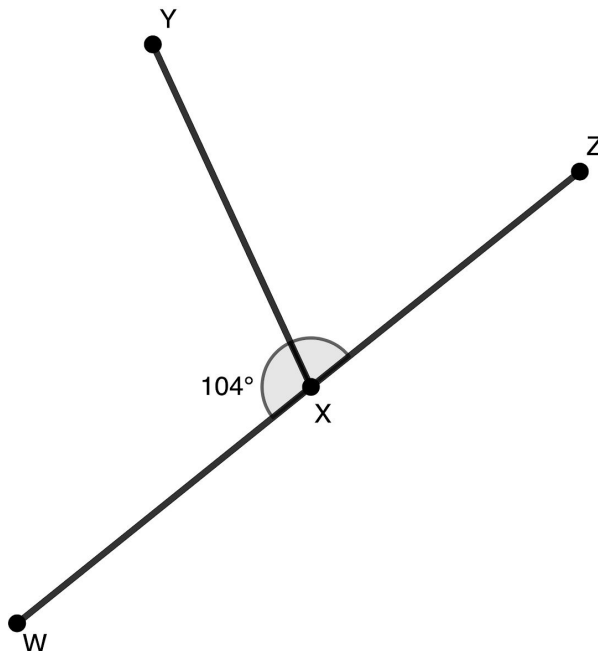

3) Consider this angle.

Which name for the angle is not correct?

- A. $\angle DUC$
- B. $\angle DUK$
- C. $\angle UDC$
- D. $\angle CUD$

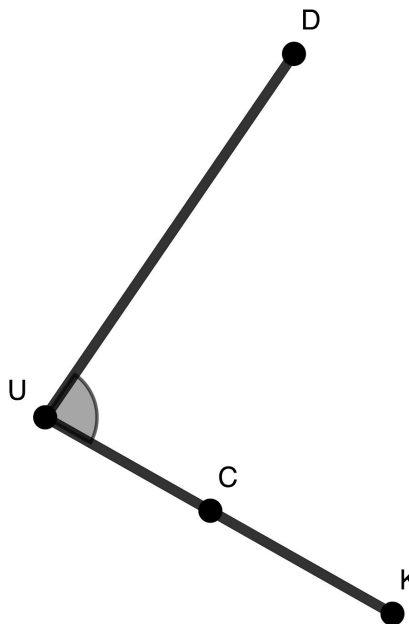

4) \overline{AL} intersects with \overline{NE} .

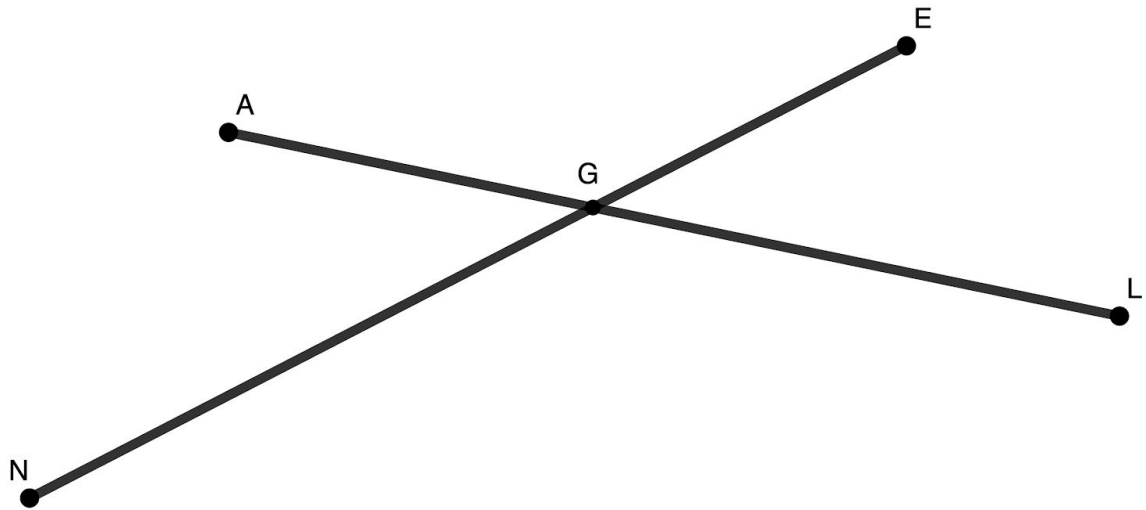

Which of the following two statements are true?

- A. $\angle AGN$ is equal to $\angle LGE$.
- B. $\angle AGN$ is equal to $\angle LGN$.
- C. $\angle AGE$ is equal to $\angle NGL$.
- D. $\angle NAG$ is equal to $\angle LEG$.

5) These two triangles are similar. What is the perimeter of the larger triangle?

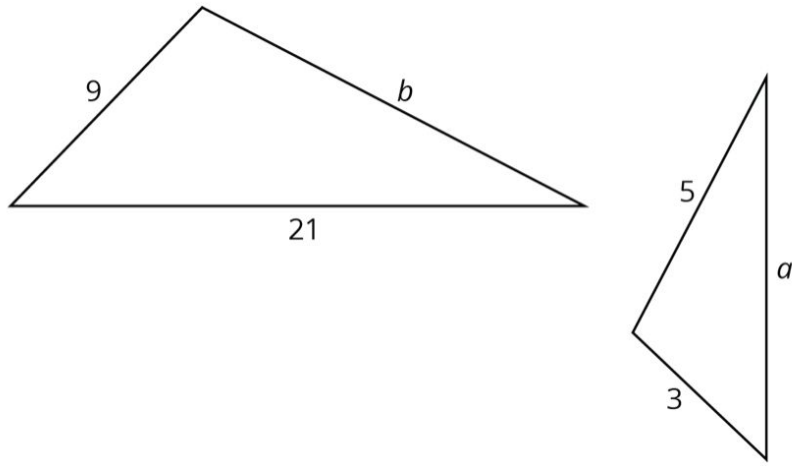

- A. 7
- B. 15
- C. 30
- D. 45

Explain why you choose your answer.

6) Below are two similar triangles.

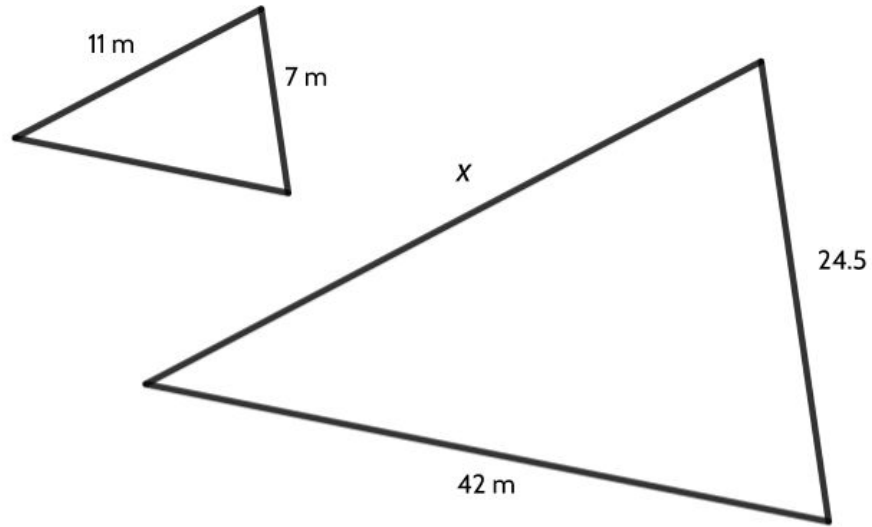

What is the length of side x ?

- A. 3.5 m
- B. 12 m
- C. 33 m
- D. 38.5 m

Explain why you choose your answer.

7) \overline{FE} intersects with \overline{AB} and \overline{CD} .

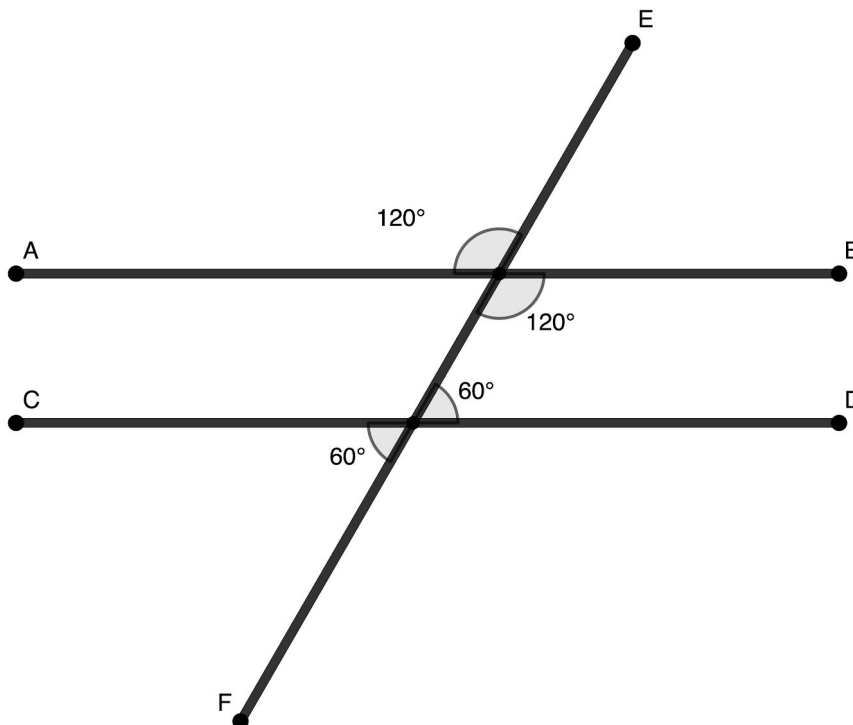

Which of the following statements is true?

- A. \overline{EF} is perpendicular to \overline{AB} .
- B. \overline{AB} is perpendicular to \overline{CD} .
- C. \overline{AB} is not parallel to \overline{CD} .
- D. \overline{AB} is parallel to \overline{CD} .

Explain why you choose your answer.

8) Which of these is a ray?

a.



b.

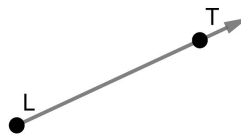

c.



d.

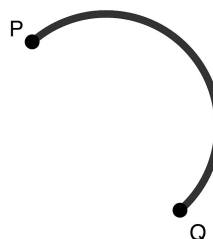

9) Which of the following could represent the lengths of the sides of a right triangle?

- A. 9, 16, 25
- B. 5, 12, 12
- C. 15, 30, 45
- D. 24, 32, 40

10) Triangle RST is shown on the right.

What is the length of \overline{ST} ?

- A. 5
- B. 8
- C. 12
- D. 18

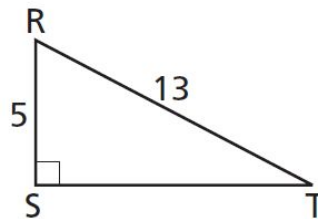

- 11) The small rectangle below has been scaled up by a dilation of 2 to create the large rectangle.

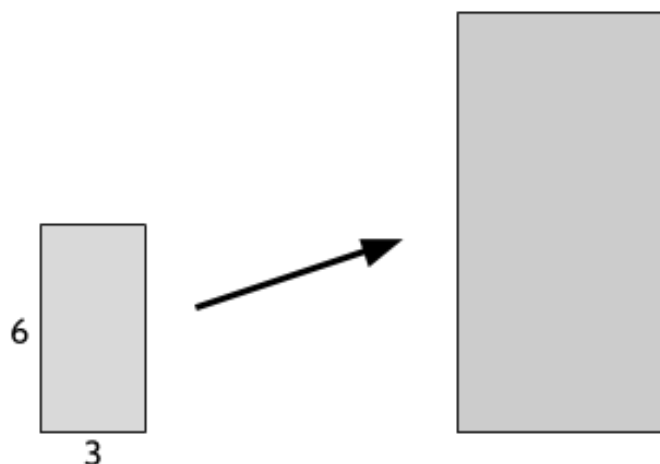

Part One:

How does dilating a rectangle by a scale factor of 2 affect its area?

- A. The area doesn't change.
- B. The area is twice as big in the larger rectangle.
- C. The area is three times as big in the larger rectangle.
- D. The area is four times as big in the larger rectangle.

Part Two:

How does dilating a rectangle by a scale factor of 2 affect its perimeter?

- A. The perimeter doesn't change.
- B. The perimeter is twice as long in the larger rectangle.
- C. The perimeter is three times as long in the larger rectangle.
- D. The perimeter is four times as long in the larger rectangle.

12) The small triangle has been dilated to create the large triangle.

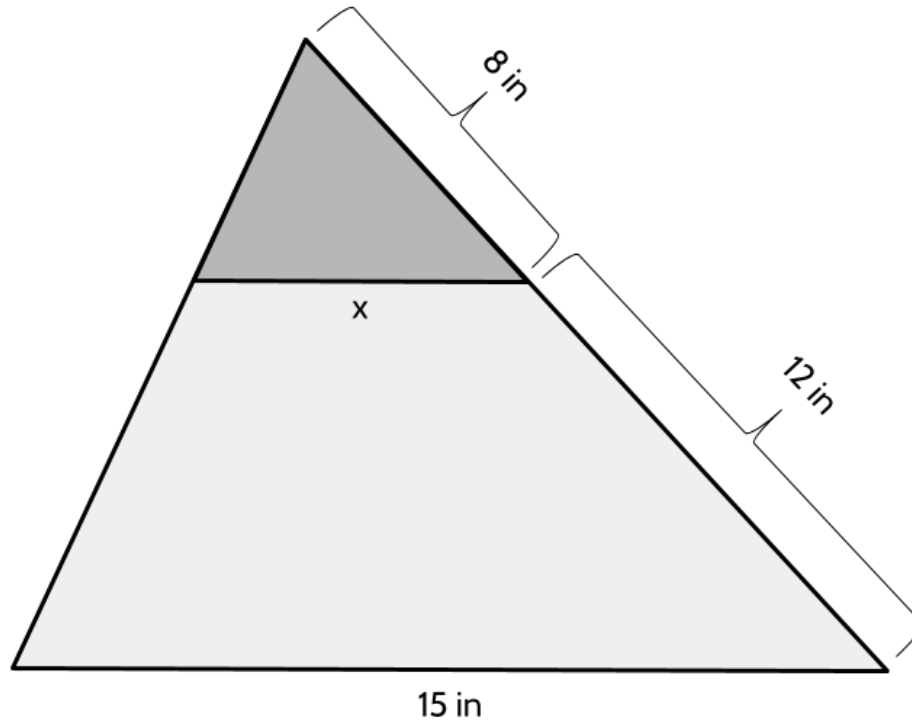

Part One:

What is the value of x ?

- A. 6 in
- B. 7 in
- C. 10 in
- D. 20 in

Part Two:

What is the scale factor of the dilation? Enter your answer in the grid on the right.

	7	7	7	
.
0	0	0	0	0
1	1	1	1	1
2	2	2	2	2
3	3	3	3	3
4	4	4	4	4
5	5	5	5	5
6	6	6	6	6
7	7	7	7	7
8	8	8	8	8
9	9	9	9	9

13) What is the length of side x in the triangle below?

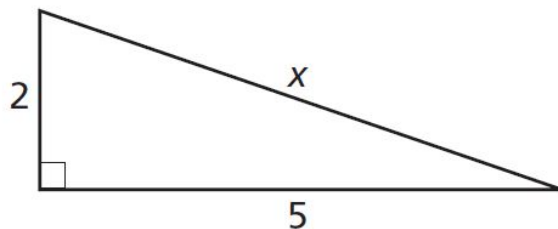

[not drawn to scale]

- A. 7
- B. $\sqrt{7}$
- C. 29
- D. $\sqrt{29}$

14) Jesse drew the triangle below.

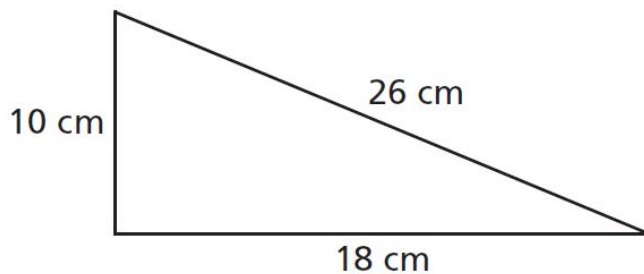

[not drawn to scale]

Is Jesse's triangle a right triangle? (Use the Pythagorean theorem to find out.)

- A. No, because $10 + 18$ doesn't equal 26.
- B. No, because $100 + 324$ equals 424, not 676.
- C. Yes, because 26 is bigger than 10 and 18.
- D. Yes, because $10 + 18$ is bigger than 26.

Test Practice Questions - Answer Key

- 1) Choice C. Choice C can be read as, "The square of the length of the hypotenuse plus the square of the length of one leg is the same as the square of the other leg. This is not true.

Choice A: Sides p and w are the legs of the right triangle and side s is the hypotenuse. Choice A can be read as, the square of leg p added to the square of leg w will be the same as the square of hypotenuse s which is true.

Choice B and Choice D: The square of the hypotenuse minus the square of one of the legs will be the same as the square of the other leg.

- 2) Choice B. $\angle WXZ$ is a straight angle (measures 180°), which means $\angle WXY$ and $\angle ZXY$ are supplementary angles. Since $\angle WXY$ measures 104° , $\angle ZXY$ measures 76° ($180^\circ - 104^\circ = 76^\circ$).
- 3) Choice C. Point U is the vertex of this angle. Any name for this angle must have U in the middle of the name.
- 4) Choices A and C are true statements. $\angle AGN$ and $\angle LGE$ are opposite angles, so they are equal. $\angle AGE$ and $\angle NGL$ are also opposite angles.
- 5) Choice D. First you need to determine the scale factor. From the corresponding sides of 3 and 9, we know the larger triangle is three times larger than the smaller triangle. The missing side length, b , of the larger triangle corresponds to the side length of 5 in the smaller triangle, so the length of b is 15. The perimeter of the larger triangle is 45 ($9 + 21 + 15$).
- 6) Choice D. 38.5 m. The only pair of corresponding sides we are given are 7 m and 24.5 m. A side length of 7 enlarged by a scale factor of 3.5 would give you 24.5 m. The corresponding side for side x is 11 m. 11 m enlarged by a scale factor of 3.5 is 38.5 m.
- 7) Choice D. When two parallel lines are intersected by a straight line, it makes two groups of opposite angles which are equal to each other. We can use the given angles to find the missing angles. The angles next to (or adjacent to) the 120° angles are 60° and the angles next to the 60° angles are 120° . Two groups of opposite and equal angles are only formed when the lines intersected are parallel to each other.

We can eliminate choices A and B because we can see that none of the lines are perpendicular. If \overline{EF} was perpendicular to \overline{AB} , they would form a 90° angle.

- 8) Choice B.

Choice A is a line. Choice C is a line segment. Choice D is an arc.

- 9) Choice D. $24^2 + 32^2 = 40^2$. The Pythagorean Theorem does not work for any of the other options.
- 10) Choice C. The length of the hypotenuse is 13. The length of one of the legs is 5. We are looking for the length of the other leg. If I build squares off each side of the triangle, the area of the square built off the hypotenuse is 169. The area of the square built off the given leg is 25. That means the area of the square built off the unknown leg plus 25 will be the same as the area of the square built off the hypotenuse, which is 169. 144 plus 25 is the same as 169. So the square built off the unknown leg has an area of 144. If a square has an area of 144, each of its sides will have a length of 12.
- 11) **Part One:** Choice D. The area is four times as big in the larger rectangle. The area of the small rectangle is 18 (3×6). The area of the large rectangle is 72 (6×12).
Part Two: Choice B. The perimeter is twice as long in the larger rectangle. The perimeter of the small rectangle is 18 ($3 + 6 + 3 + 6$). The perimeter of the large rectangle is 36 ($6 + 12 + 6 + 12$).
- 12) **Part One:** Choice A. One side of the small triangle is 8 in. The corresponding side of the large triangle is 20 in ($8 + 12$). $20 \div 8 = 2.5$ (scale factor). $2.5x = 15 \rightarrow x = 6$
Part Two: 2.5 (see above)
- 13) Choice D.

leg ²		leg ²		hypotenuse ²
5 ²	+	2 ²	=	x ²
25		4		29

$\sqrt{29}$ can be read as “what number times itself is the same as 29?” or “what is the square root of 29?”. Of the available choices, this is the only answer that is true.

- 14) Choice B.

This is not a right triangle because the sum of the area of the squares built off the two shorter sides is not the same as the area built off the longest side. We can square the length of the legs. $10^2 + 18^2$ is the same as $100 + 324$. $100 + 324$ is equal to 424. That means the sum of the area of the two squares built off the shorter sides is 424. But here the longest side of the triangle measures 26, and 26^2 is not the same as 324, so the triangle cannot be a right triangle.

Reviewing What We Have Learned About Lines, Angles, and Shapes

Below is a list of some the skills you have worked on in Part 1 and Part 2. Write a checkmark ✓ next to each statement you agree with. If there are any areas you are not sure about, go back and review those sections.

I understand...

- when to use length, area, and volume
- the difference between a line, a segment, and a ray
- the definitions of parallel and perpendicular lines
- how to name:
 - lines, segments, rays
 - angles
- how to use the definition of complementary angles to find missing angles
- how to use the definition of supplementary angles to find missing angles
- what happens when two lines intersect to form four angles
- how to use angles to determine if two lines are parallel
- when to use perimeter and when to use area
- why 7^2 can be read as “seven *squared*”
- How to find the square root of a number
- how to use the lengths of two sides of a right triangle to find the length of the missing side
- how to use the lengths of the sides of a triangle to determine if it is a right triangle
- how to use the lengths of the sides of a triangle that is dilated by a scale factor to determine the lengths of the sides of the enlarged/reduced similar triangle
- how to determine the scale factor using the lengths of the sides of similar triangles
- the definitions of: circle, radius, diameter, circumference
- the relationship between the diameter and the circumference of a circle

The Language of Geometry

Concept Circle

Explain these words and the connections you see between them.

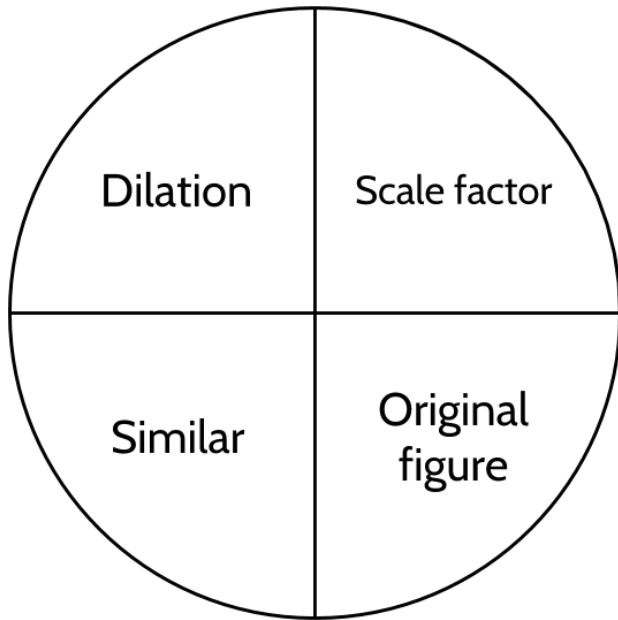
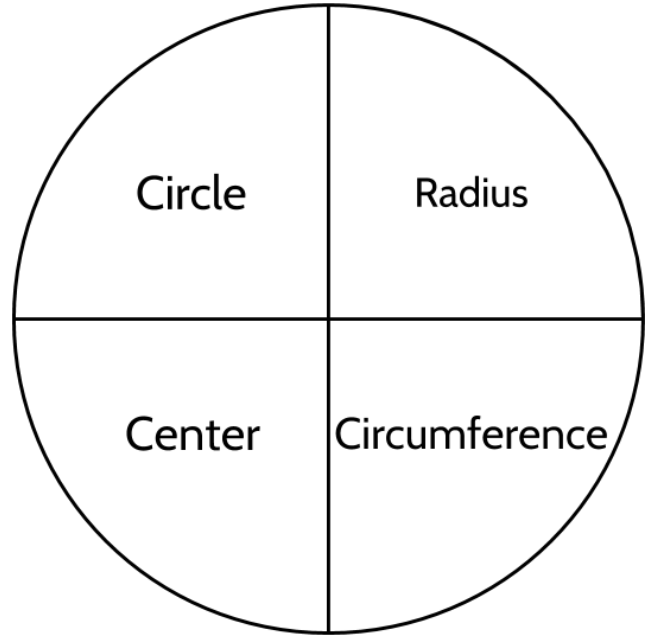

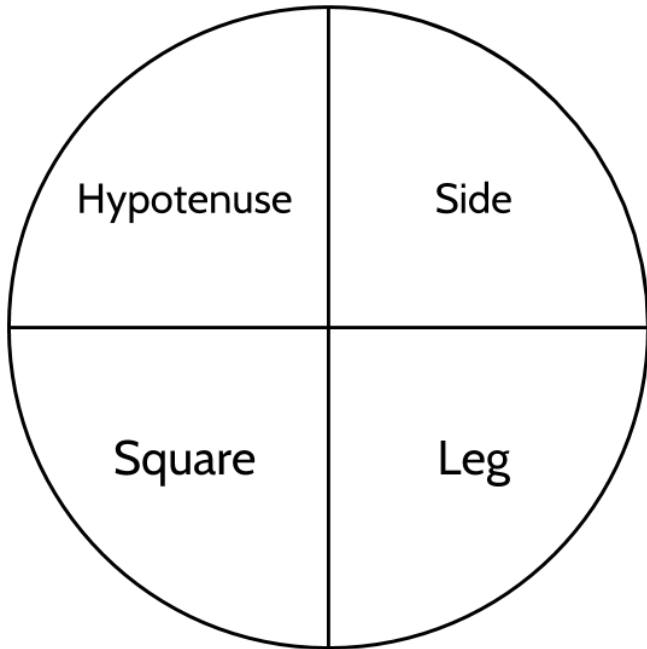
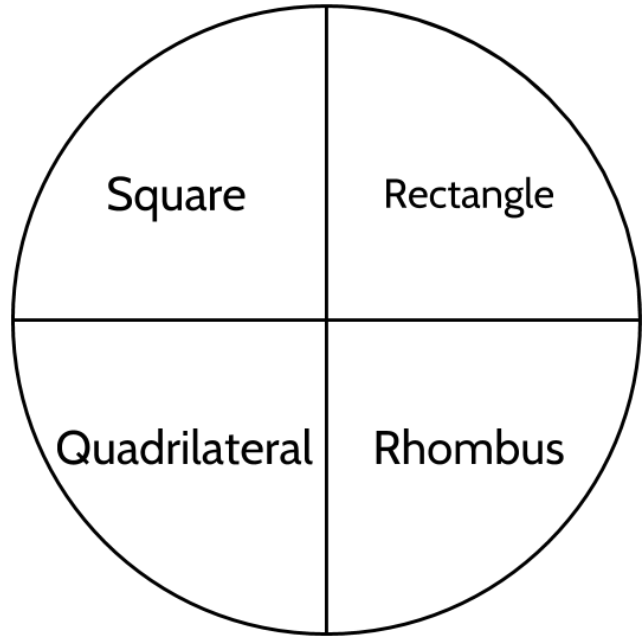

Glossary and Vocabulary Review

acute angle (noun): an angle that is less than 90° . (See ANGLE)

adjacent (adjective): next to something. In geometry we sometimes describe angles as being adjacent to each other when they are next to one another and share one side.

angle (noun): the opening between two rays or line segments that have a common endpoint. We call that endpoint the vertex. In the angle on the right, point Y is the vertex. We can name the angle $\angle PYT$ or $\angle TYP$. Note that the vertex has to be the middle letter. We measure angles using degrees.

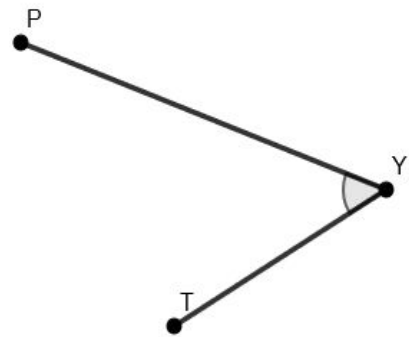

(See OBTUSE ANGLE, ACUTE ANGLE, RIGHT ANGLE, STRAIGHT ANGLE, VERTEX, SUPPLEMENTARY ANGLES, COMPLEMENTARY ANGLES)



Right Angle (90°)

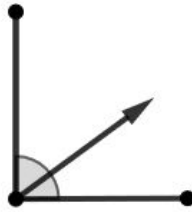

Complementary Angles



Acute Angle

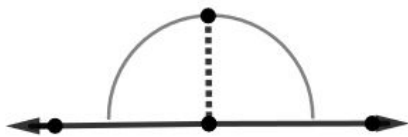

Straight Angle (180°)

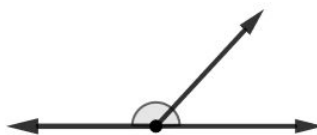

Supplementary Angles



Obtuse Angle

area (noun): The size of a surface. When we talk about area, we are talking about how many square units it would take to cover a surface.

characteristic (noun): A special quality or feature that someone or something has, and that makes that person or thing different from others. Other words that have a similar meaning are: quality, trait, attribute, feature, property.

circle (noun): a two-dimensional figure in which every point is the same distance from a point called the center. (See CIRCUMFERENCE, DIAMETER, RADIUS)

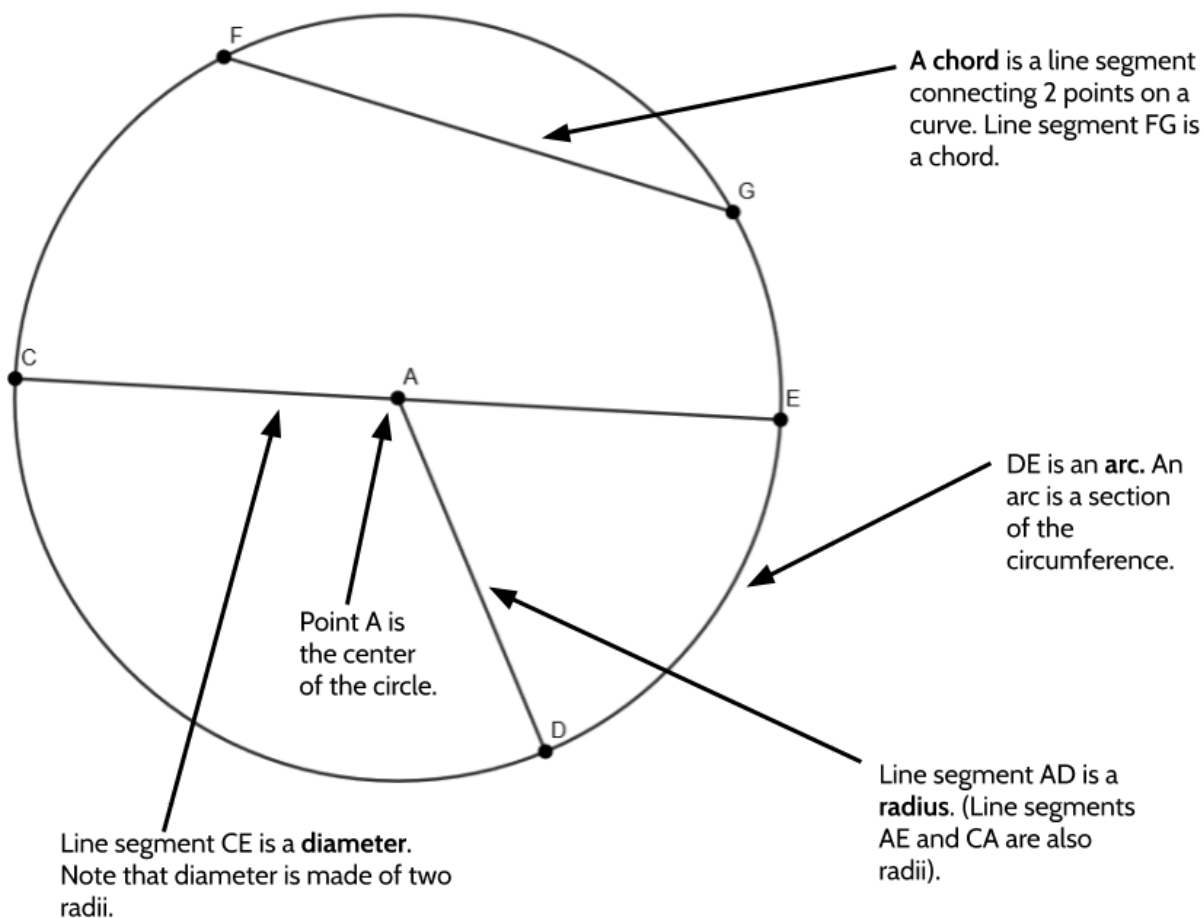

circumference (noun): The distance around a circle. You may think of the circumference as the perimeter of a circle. The circumference of every circle is a little more than three times the length of the diameter of the circle. To be more exact, the circumference of a circle is equal to pi (π) times the length of the diameter. In the circle above, the circumference is the distance from point C to point F to point G to point E to point D and back to point C. That distance is a little more than three times the length of line CE.

compare (verb): to describe how two or more things are alike or different.

complementary angles (noun): (See ANGLE, RIGHT ANGLE)

cone (noun): a hollow or solid three-dimensional shape with a round base and a point opposite that base.

corresponding sides (noun): Corresponding sides have the same basic position in similar figures. Corresponding sides are related to each other by a scale factor. (See SCALE FACTOR, DILATION)

cube (noun): A three-dimensional shape with six identical square faces. A cube is a special type of rectangular prism.

cylinder (noun): a shape with circular ends and long straight sides.

degree (noun): a degree is the unit used to measure angles. Degrees describe the opening in an angle.

diameter (noun): a line segment that goes from one point on a circle, through the center of the circle, to another point on the circle. *See Circle*

dilation (noun): a dilation is a *non-rigid* transformation that makes a figure larger or smaller without changing its shape. Dilations can be described by the term *scale factor*. In this diagram, $\triangle ABC$ is dilated by a scale factor of 2. That means the image is 2 times larger than the original figure. A scale factor of $\frac{1}{2}$ means that the dilated image is half the size of the original figure.

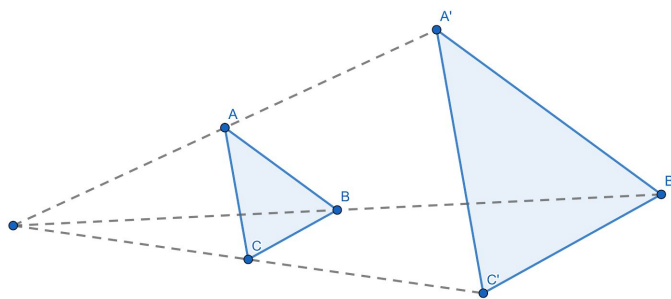

equilateral triangle (noun): a triangle with all sides the same length. All three angles in an equilateral triangle will be 60° .

estimate (verb): to find an approximate answer that is somewhat close to an exact amount.

length (noun): The measurement of something from one end to the other. The distance between two points

line (noun): A line is an infinite set of points continuing in opposite directions without end.

line segment (noun): a line segment is part of a line, defined by two endpoints and all the points between them. You can think of the rungs of a ladder as physical examples of line segments.

net (noun): a two-dimensional pattern that can be folded into a three-dimensional figure.

obtuse angle (noun): an angle that is larger than 90° and smaller than 180° (See ANGLE.)

opposite angles (noun): Opposite angles are the angles that are opposite each other when two lines cross. Opposite angles are sometimes called vertical angles because they share a vertex. Opposite angles are equal.



parallel lines (noun): parallel lines are lines on a plane that never meet.

parallelogram (noun): a quadrilateral with opposite sides parallel. Opposite angles are also equal. A rectangle, rhombus, and square are all examples of special parallelograms.

perimeter (noun): the whole length of the border around an area or shape.

perpendicular lines (noun): perpendicular lines are lines that intersect to form 90° angles.

pi (π): Pi is the 16th letter in the Greek alphabet. It is used in math to represent a special relationship found in any circle in the world. The circumference of any circle in the world is about 3 times greater than the diameter of that circle. If you divide the length around any circle (circumference) by the length across it (diameter), you will get something close to 3.14. (See CIRCLE, CIRCUMFERENCE, DIAMETER.)

plane (noun): a completely flat surface

point (noun): a point has no size, it is only a location and it is named with a capital letter.

polygon (noun): polygons are shapes that are formed by straight line segments so that each segment meets exactly two other segments.

protractor (noun): a tool that allows us to measure the number of degrees in an angle. As a ruler allows us to measure length, a protractor allows us to measure angles.

radius (noun): a line segment from the center of a circle to any point on the circle. The radius is half of the diameter. The way to describe more than one radius is "radii" (pronounced ray-dee-i). Every radii in a circle is the same length.

ray (noun): a ray is a part of a line. It starts with one endpoint and extends infinitely in one direction.

rectangle (noun): a parallelogram with all right angles. Squares are a special kind of rectangle.

rhombus (noun): a quadrilateral that has all sides the same length. Opposite sides are parallel and opposite angles are equal.

right angle (noun): a right angle is an angle that measures 90° . All four angles in a square or rectangle are right angles. (See ANGLE, COMPLEMENTARY ANGLES)

right triangle (noun): a right triangle is a triangle with one 90° angle. In a right triangle, the side opposite the right angle is called the *hypotenuse*. The two sides that form the right angle are called *legs*.

scale factor (noun): The number used to multiply the lengths of a figure to enlarge or shrink an image. If we have a scale factor of 2, all of the lengths in the image are 2 times longer as the corresponding lengths in the original. When you are given two corresponding lengths, if you divide them, you get the scale factor. (See DILATION)

similar triangles (noun): similar triangles are triangles that are the same shape, but different sizes.

sphere (noun): a solid object in the shape of a ball. In a sphere, every point on the surface is exactly the same distance from the center of the sphere.

square (noun): a rectangle with all four sides the same length.

supplementary angles (noun): two angles that together form a straight line are called supplementary angles. The two supplementary angles add up to 180° . (See ANGLE, SUPPLEMENTARY ANGLES)

surface area (noun): The area on the surface of a 3-dimensional figure. For example, the amount of wrapping paper on a gift would be measured in surface area. (See AREA.)

theorem (noun): A statement that can be shown to be true, especially in math.

triangle (noun): a flat shape with three straight sides and three angles. The sum of all three angles in any triangle is 180°

unit cube (noun): a cube whose edges are 1 unit in length. A unit cube is the basic unit of measure we use for volume. (Examples of unit cubes: cubic feet, cubic inch, cubic yard, etc.)

unit square (noun): a square whose sides are 1 unit in length. A square unit is the basic unit of measure we use for area. (Examples of unit squares: square feet, square inch, square mile, etc.)

vertical angles (noun): vertical angles are opposite angles formed when two lines intersect. Vertical angles are equal - they measure the same number of degrees.

vertex (noun): The vertex is the point where the segments, rays, or lines intersect to form an angle. (See ANGLE)

volume (noun): the amount of space inside a three-dimensional object or the amount of space that object takes up. For example, when we talk about the volume of a cereal box, we would be talking about the amount of space inside the box. If we were talking about the volume of an apple, we would be talking about how much space the apple takes up. When we talk about volume, we are talking about how many unit cubes it could take to fill the object.