

Test and Item Specifications

Mathematics

Developed and published by Data Recognition Corporation, 13490 Bass Lake Road, Maple Grove, MN 55311. Copyright © 2016 by Data Recognition Corporation. All rights reserved. No part of this publication may be reproduced or distributed in any form or by any means, or stored in a database or retrieval system, without the prior written permission of the publisher.

TASC Test Assessing Secondary Completion is a trademark of Data Recognition Corporation. Data Recognition Corporation is not affiliated with The After-School Corporation, which is known as TASC. The After-School Corporation has no affiliation with the Test Assessing Secondary Completion (“TASC test”) offered by Data Recognition Corporation, and has not authorized, sponsored or otherwise approved of any of Data Recognition Corporation’s products and services, including TASC test.

The following test and item specifications are included in this section for the TASC Mathematics subtest.

- 1) Mathematics Blueprint
 - a) 2015—2016 (Forms DEF)
 - b) 2016—2017 (Forms GHI)

- 2) Mathematics Subtest Form Design
 - a) Design Table
 - b) Testing Times

- 3) TASC Mathematics Item Specifications for Measured Standards
 - o Domain
 - o Subdomain
 - o Standard
 - o Emphasis Level
 - o Evidence Statements
 - o Assessment Limits/Content Constraints
 - o DOK(s)
 - o Sample Item Stem(s)¹
 - o Sample Item(s)

- 4) Other TASC Mathematics Test Specifications
 - a) Scoring Rules
 - b) Constructed Response Scoring Rubrics
 - c) Calculator Specifications

¹ Sample Item Stems are examples of item stems that may be used; items are not limited to the examples shown in this document.

1) Mathematics Blueprint

a) 2015 – 2016 (Forms D, E, and F) and 2016 – 2017 (Forms G, H, and I)

Domain/ Reporting Category	Subdomain/Core Idea	Subdoma in %	Domain %
Algebra	Arithmetic with Polynomials and Rational Expressions	6%	26%
	Reasoning with Equations and Inequalities	8%	
	Creating Equations	6%	
	Seeing Structure in Expressions	6%	
Geometry	Geometric Measurement with Dimension	6%	23%
	Modeling with Geometry	7%	
	Congruence	5%	
	Similarity, Right Triangles, and Trigonometry	5%	
Functions	Interpreting Functions	10%	26%
	Linear, Quadratic, and Exponential Models	8%	
	Building Functions	8%	
Number and Quantity	Quantities	10%	13%
	The Real Number System	3%	
Statistics and Probability	Making Inferences and Justifying Conclusions	3%	12%
	Interpreting Categorical and Quantitative Data	6%	
	Conditional Probability and Rules of Probability	3%	

Note: While the blueprint for 2016 – 2017 (Forms, G, H, and I) is the same as 2015 – 2016 (Forms D, E, and F), some of the standards assessed within each Domain / Reporting Category have changed.

2) Test Form Design

In each operational year, three equated operational forms are selected for each subtest. The first operational TASC forms in 2014 were comprised of 35 multiple-choice (MC) items and 10 gridded-response (GR) items. In the 2015 and 2016 forms, other autoscored items (such as multiple selected-response items and technology-enhanced items such as drag-and-drop or matching items) and constructed-response (CR) items are being field tested and may be included as operational items in future years.

The table below shows the projected item numbers by item type in the 2016 forms. Research and data may necessitate minor adjustments to these numbers.

a) Design Table

Item Type	Total Items per Form	Testing Time: (minutes)
Multiple Choice (MC)	43	64.5
GR	12	24
1-point Autoscored	1	2
2-point Autoscored	1	3
Constructed Response (CR)	1	4

b) Testing Times are based on these estimates.

Item Type	Estimated Testing Time (minutes)
MC	1.5
GR	2
1-pt Autoscored	2
2-pt Autoscored	3
CR	4

3) Item Specifications for Measured Standards

Item specifications are one of the key requirements for a high-quality, legally defensible standards-based assessment. Item specifications help define important characteristics of the items (i.e., test questions) developed for each standard. These item specifications provide guidelines to help clarify the focus of what is to be assessed, what items may include, and what items may not include (i.e., assessment limits). Item specifications are used by item writers, item editors, and item reviewers as a common reference throughout the item-development process, from initial writing to final approval. The TASC Mathematics item specifications are based on the TASC test standards for Mathematics, which are based on the College and Career Readiness for Adult Education (CCR-AE) standards. The assessment limits/content constraints have been further refined based on customer feedback and DRC | CTB item-performance data analyses targeting specific standard- and item-level assessment scope.

Domain	A—Algebra
Subdomain	A.CED—Creating Equations
Standard	A.CED.1: Create equations and inequalities in one variable and use them to solve problems. <i>Include equations arising from linear and quadratic functions, as well as simple rational and exponential functions.</i>
Emphasis Level	High
Evidence Statements	<p>The examinee will demonstrate an understanding of creating one-variable equations arising from linear, quadratic, simple rational, and exponential functions in one variable.</p> <p>The examinee will demonstrate an understanding of creating one-variable inequalities arising from linear, quadratic, simple rational, and exponential functions in one variable.</p>
Assessment Limits / Content Constraints	<ul style="list-style-type: none"> • Make sure items use equations (not expressions) and that the final equations have just one variable. • Emphasis is placed on creating linear equations. • Provide a context. • Stimulus may be a literal description, a graph, a table or some combination of these. • Exponents are limited to integers.
DOK(s)	2
Sample Item Stem(s)	Which equation can be used to find... Which inequality can be used to determine...

Sample Item

During a sale, an appliance that costs \$275.00 is being sold at a discount for \$220.00. Which equation can be used to find the rate of the discount, d , during the sale?

- A. $220 - d = 275$
- B. $275 - d = 220$
- C. $220 - 220d = 275$
- D. $275 - 275d = 220$ (Correct response)

Domain	A—Algebra
Subdomain	A.CED—Creating Equations
Standard	A.CED.2: Create equations in two or more variables to represent relationships between quantities; graph equations on coordinate axes with labels and scales.
Emphasis Level	High
Evidence Statements	<p>The examinee will demonstrate an understanding of graphing equations on coordinate axes with labels and scales to represent the solution to a contextual problem.</p> <p>The examinee will demonstrate an understanding of creating equations in two or more variables to represent relationships between quantities.</p>
Assessment Limits / Content Constraints	<ul style="list-style-type: none"> • Limit to linear equations and two variables. • Provide a context. • Stimulus may be a literal description, a graph, a table, or some combination of these.
DOK(s)	2
Sample Item Stem(s)	<p>Which equation shows the relationship of the variables represented in the table/graph?</p> <p>Which graph represents the equation?</p>

Sample Item

The graph shows the distance between an airplane in flight and its destination airport.

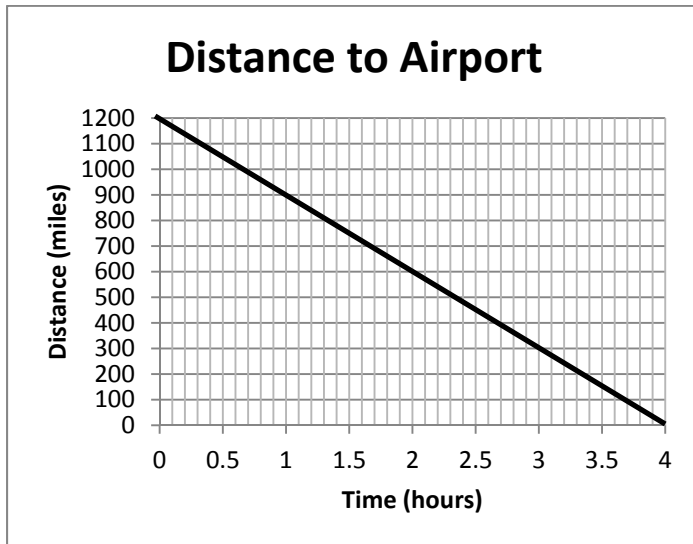

Which equation can be used to calculate the distance, d , between the airplane and the airport in relation to the number of hours, h , that the airplane has been flying?

- A. $d = 300h$
- B. $d = -300h$
- C. $d = 1,200 + 300h$
- D. $d = 1,200 - 300h$ (Correct response)

Domain	A—Algebra
Subdomain	A.CED—Creating Equations
Standard	A.CED.3: Represent constraints by equations or inequalities and by systems of equations and/or inequalities, and interpret solutions as viable or non-viable options in a modeling context. For example, represent inequalities describing nutritional and cost constraints on combinations of different foods.
Emphasis Level	High
Evidence Statements	<p>The examinee will demonstrate an understanding of writing and use a system of equations and/or inequalities to solve a real-world problem.</p> <p>The examinee will demonstrate an understanding of recognizing that the equations and inequalities represent the constraints of the problem.</p>
Assessment Limits / Content Constraints	<ul style="list-style-type: none"> • Limit to linear equations. • Provide a context. • Stimulus may be a literal description, a graph, or some combination of these.
DOK(s)	2
Sample Item Stem(s)	<p>Which system of equations represents....</p> <p>What does the solution (8, 25) represent in the context of the problem?</p> <p>Which graph represents this situation?</p>

Sample Item

Small boxes and large boxes are stacked together on a pallet.

- The total number of boxes is 10.
- The small boxes weigh 5 pounds each.
- The large boxes weigh 12 pounds each.
- The total weight of the boxes is 78 pounds.

Which system of equations can be used to find the number of small boxes, x , and large boxes, y , on the pallet?

- | | | |
|--|---------------------------|--|
| <p>A. $x + y = 10$
$5x + 12y = 78$</p> | <p>(Correct response)</p> | <p>C. $x + y = 78$
$5x + 12y = 10$</p> |
| <p>B. $x + y = 10$
$5x + 12y = 10$</p> | | <p>D. $x + y = 78$
$5x + 12y = 78$</p> |

Domain	A—Algebra
Subdomain	A.CED—Creating Equations
Standard	A.CED.4: Rearrange formulas to highlight a quantity of interest, using the same reasoning as in solving equations. For example, rearrange Ohm’s law $V = IR$ to highlight resistance R .
Emphasis Level	Low
Evidence Statements	<p>The examinee will demonstrate the ability to solve a multi-variable equation for a given variable.</p> <p>The examinee will be able to identify the variable of interest in a given situation.</p>
Assessment Limits / Content Constraints	<ul style="list-style-type: none"> • Limit to linear and quadratic equations. • Use either real-world formulas or a context that established the relevance of the formula.
DOK(s)	2
Sample Item Stem(s)	<p>Solve the equation... for t.</p> <p>Rewrite the equation so that it demonstrates the hourly rate of pay.</p>

Sample Item

Albert Einstein’s theory of relativity is $E=mc^2$ where E is energy, m is mass and c is the speed of light. State the equation in terms of mass.

A. $m = Ec^2$

B. $m = \frac{c^2}{E}$

C. $m = \frac{E}{c^2}$ (Correct response)

D. $m = \sqrt{Ec}$

Domain	A—Algebra
Subdomain	A.APR—Arithmetic with Polynomials and Rational Expressions
Standard	A.APR.1: Understand that polynomials form a system analogous to the integers, namely, that they are closed under the operations of addition, subtraction, and multiplication; add, subtract, and multiply polynomials.
Emphasis Level	High
Evidence Statements	<p>The examinee will demonstrate an understanding of adding or subtracting polynomials.</p> <p>The examinee will demonstrate an understanding of multiplying polynomials.</p> <p>The examinee will demonstrate an understanding of dividing polynomials by integers or monomials.</p>
Assessment Limits / Content Constraints	<ul style="list-style-type: none"> Item could be written to standard 7.EE.1: Apply properties of operations as strategies to add, subtract, factor, and expand linear expressions with rational coefficients. Context is not required. Focus on polynomial expressions that simplify to forms that are linear or quadratic in a positive integer power of x. Arithmetic with polynomials limited to linear and quadratic polynomial expressions. Division of polynomials will be limited to division by a monomial.
DOK(s)	1, 2, or 3
Sample Item Stem(s)	<p>Simplify $(3x^2 + 6x) \div 3$.</p> <p>Divide $(3x^2 + 6x) \div 3x$.</p>

Sample Item

An accountant is using the expressions $(3a + 5b + 2c)$ and $(7a + 4c)$ to calculate the total compensation for employees in two departments of a business.

What is the sum of the two expressions?

- A. $29a$
- B. $10a + 11b$
- C. $10a + 5b + 6c$ (Correct response)
- D. $10a + 9b + 2c$

Domain	A—Algebra
Subdomain	A.APR—Arithmetic with Polynomials and Rational Expressions
Standard	A.APR.3: Identify zeros of polynomials when suitable factorizations are available, and use the zeros to construct a rough graph of the function defined by the polynomial.
Emphasis Level	High
Evidence Statements	The examinee will demonstrate an understanding of identifying zeros in a polynomial. The examinee will demonstrate an understanding of sketching a graph of a polynomial, using the zeros.
Assessment Limits / Content Constraints	<ul style="list-style-type: none"> Context is not required. Limited to quadratic functions. Graphs may be provided to help examinees “see” the zeros of a polynomial. Factors may be provided to help examinees find the zeros.
DOK(s)	1, 2, or 3
Sample Item Stem(s)	Which equation can be used to find the zeroes of ... What are the zeroes of the function defined by the equation ... What are the zeroes of the function shown in the graph?

Sample Item

Which equation could be used to find the zeros of $y = x^2 - 3x - 10$?

- A. $(x - 2)(x + 5) = 0$
 B. $(x + 2)(x - 5) = 0$ (Correct response)
 C. $(x + 2)(x - 10) = 0$
 D. $(x + 2)(x + 10) = 0$

Domain	A—Algebra
Subdomain	A.REI—Reasoning with Equations and Inequalities
Standard	A.REI.1: Explain each step in solving a simple equation as following from the equality of numbers asserted at the previous step, starting from the assumption that the original equation has a solution. Construct a viable argument to justify a solution method.
Emphasis Level	High
Evidence Statements	<p>The examinee will demonstrate an understanding of explaining steps in solving simple equations, using the equality of numbers.</p> <p>The examinee will demonstrate an understanding of constructing viable arguments to justify solution methods.</p>
Assessment Limits / Content Constraints	<ul style="list-style-type: none"> • Justifications may include the associative, commutative, and division properties, combining like terms, multiplication by 1, etc. • Properties of operations can be used to change expressions on either side of the equation to equivalent expressions. • Limit to solving linear equations—avoid operations associated with quadratic, exponential, or logarithmic equations.
DOK(s)	2 or 3
Sample Item Stem(s)	<p>Which statement explains why the equation in Step 3 is equivalent to Step 2?</p> <p>Which property was used to get from the equation in Step 1 to the equation in step 2?</p>

Sample Item

Consider the steps that a mathematician writes as she solves the equation $5x + 2 = 3x - 7$.

$$\begin{array}{ll} \text{Equation:} & 5x + 2 = 3x - 7 \\ \text{Step 1:} & 2x + 2 = -7 \\ \text{Step 2:} & 2x = -9 \\ \text{Solution:} & x = -\frac{9}{2} \end{array}$$

Which statement explains why the solution following Step 2 is a valid step?

- If you add 2 to both sides of an equation, the sides remain equal.
- If you divide both sides of an equation by 2, the sides remain equal. (Correct response)
- If you multiply both sides of an equation by 2, the sides remain equal.
- If you subtract 2 from both sides of an equation, the sides remain equal.

Domain	A—Algebra
Subdomain	A.REI—Reasoning with Equations and Inequalities
Standard	A.REI. 2: Solve simple rational and radical equations in one variable, and give examples showing how extraneous solutions may arise.
Emphasis Level	Low
Evidence Statements	<p>The examinee will demonstrate an understanding of solving radical and/or simple rational equations in one variable, including identifying the number and type of real solutions that might exist for the equation (e.g., one, two, infinite, or no real solutions).</p> <p>The examinee will demonstrate an understanding of evaluating proposed solutions to radical or simple rational equations and recognize where extraneous solution(s) might arise during the solving of the equation.</p>
Assessment Limits / Content Constraints	<ul style="list-style-type: none"> • Limit to simple, non-quadratic, rational equations. • Limit to radical equations with real roots. • Solutions must be rational numbers.
DOK(s)	2 or 3
Sample Item Stem(s)	What is the solution to the equation ...

Sample Item

What is the solution to the equation $\sqrt{4x} = 10$?

Domain	A—Algebra
Subdomain	A.REI—Reasoning with Equations and Inequalities
Standard	A.REI.3: Solve linear equations and inequalities in one variable, including equations with coefficients represented by letters.
Emphasis Level	High
Evidence Statements	<p>The examinee will demonstrate an understanding of solving linear equations in one variable, with numeric coefficients.</p> <p>The examinee will demonstrate an understanding of solving linear inequalities in one variable, with numeric coefficients.</p> <p>The examinee will demonstrate an understanding of solving literal equations or inequalities for a stated variable.</p> <p>The examinee will demonstrate an understanding of interpreting specific given information to assign a value for a coefficient in a linear equation or inequality.</p>
Assessment Limits / Content Constraints	<ul style="list-style-type: none"> • Context is not required. • Solutions may be real numbers of any form (integers, decimals, fractions). • Do not include compound inequalities.
DOK(s)	2 or 3
Sample Item Stem(s)	Given $y = mx + b$, solve for x .

Sample Item

The equation $0.25x - 50 = 240$ can be used to find the total height of a ramp, in meters, given the distance, x , in meters, from the beginning of the ramp.

What is the value of x in meters?

(Correct response: 1,160 meters)

Domain	A—Algebra
Subdomain	A.REI—Reasoning with Equations and Inequalities
Standard	A.REI.4: Solve quadratic equations in one variable.
Element	A.REI.4a: Use the method of completing the square to transform any quadratic equation in x into an equation of the form $(x - p)^2 = q$ that has the same solutions. Derive the quadratic formula from this form.
Emphasis Level	High
Evidence Statements	The examinee will demonstrate an understanding of solving quadratic equations in one variable by completing the square.
Assessment Limits / Content Constraints	<ul style="list-style-type: none"> • Limit to rational and irrational roots. • Present quadratics in standard form: $ax^2 + bx + c = 0$.
DOK(s)	2 or 3
Sample Item Stem(s)	Which of these quadratic equations can easily be solved by completing the square? Derive the quadratic formula by completing the square for...

Sample Item

Which of these shows an equivalent form of $x^2 + 6x + 7 = 0$ by completing the square?

- A. $(x - 3)^2 = 16$
- B. $(x + 3)^2 = 16$
- C. $(x - 3)^2 = 2$
- D. $(x + 3)^2 = 2$ (Correct response)

Domain	A—Algebra
Subdomain	A.REI—Reasoning with Equations and Inequalities
Standard	A.REI.4: Solve quadratic equations in one variable.
Element	A.REI.4b: Solve quadratic equations by inspection (e.g., for $x^2 = 49$), taking square roots, completing the square, using the quadratic formula, and factoring, as appropriate to the initial form of the equation. Recognize when the quadratic formula gives complex solutions and write them as $a \pm bi$ for real numbers a and b .
Emphasis Level	High
Evidence Statements	<p>The examinee will demonstrate an understanding of solving quadratic equations in one variable by taking square roots, completing the square, using the quadratic formula, or by factoring.</p> <p>The examinee will demonstrate an understanding of recognizing when the quadratic formula indicates that there will be no real solutions.</p>
Assessment Limits / Content Constraints	<ul style="list-style-type: none"> Context is not required. Focus on quadratic equations with rational or irrational roots.
DOK(s)	2 or 3
Sample Item Stem(s)	Solve the following quadratic equation (by factoring, completing the square, using square roots, using the quadratic formula).

Sample Items

1. Consider the equation $x^2 = 16$.

For $x \geq 0$, what is the value of x ?

(Correct response: 4)

2. An object is launched at 14.7 meters per second (m/s) from a 49-meter tall platform. The equation for the object's height s at time t seconds after launch is $d(t) = -4.9t^2 + 14.7t + 49$, where d is in meters. When does the object strike the ground?

(Correct response: 5 seconds)

Domain	A—Algebra
Subdomain	A.REI—Reasoning with Equations and Inequalities
Standard	A.REI.6: Solve systems of linear equations exactly and approximately (e.g., with graphs), focusing on pairs of linear equations in two variables.
Emphasis Level	Low
Evidence Statement	The examinee will demonstrate an understanding of solving a system of linear equations in two variables, using both algebraic methods and interpreting solutions with graphs.
Assessment Limits / Content Constraints	<ul style="list-style-type: none"> • Can have context or no context; both are acceptable. • Limited to two linear equations. • Stimulus may include a graph.
DOK(s)	2 or 3
Sample Item Stem(s)	At which point do the two linear equations intersect? Which values of x and y satisfies both equations? Solve the system of equations.

Sample Items

1. Consider the system of equations.

$$y = 5x - 2$$

$$y = 7x + 10$$

Which ordered pair is the solution to the system of equations?

- A. (-4, -18)
- B. (-6, -32) (Correct response)
- C. (4, 22)
- D. (6, 28)

2. The Broadway theater contains 1,200 seats, with three different prices. The seats cost \$45 dollars per seat and \$60 per seat. The theater needs to gross \$63,750 on seat sales. There are twice as many \$60 seats as \$45 seats. How many seats in each level need to be sold?

(Correct response: 550 \$45 seats and 650 \$60 seats)

Domain	A—Algebra
Subdomain	A.REI—Reasoning with Equations and Inequalities
Standard	A.REI.7: Solve a simple system consisting of a linear equation and a quadratic equation in two variables algebraically and graphically. For example, find the points of intersection between the line $y = -3x$ and the circle $x^2 + y^2 = 3$.
Emphasis Level	Medium
Evidence Statement	The examinee will demonstrate an understanding of solving a system of a linear equation and a quadratic equation in two variables, using both algebraic methods and interpreting solutions with graphs.
Assessment Limits / Content Constraints	<ul style="list-style-type: none"> • Can have context or no context; both are acceptable. • Limited to one linear equation and one quadratic equation. • Stimulus may include a graph.
DOK(s)	2 or 3
Sample Item Stem(s)	What are the solutions for the system of $y = -2x + 1$ and $y = x^2 - 2$?

Domain	A—Algebra
Subdomain	A.REI—Reasoning with Equations and Inequalities
Standard	A-REI.10: Understand that the graph of an equation in two variables is the set of all its solutions plotted in the coordinate plane, often forming a curve (which could be a line).
Emphasis Level	High
Evidence Statements	<p>The examinee will demonstrate an understanding that the graph of an equation in two variables is the set of all its solutions plotted in the coordinate plane, often forming a curve (which could be a line).</p> <p>The examinee will demonstrate an understanding by explaining and verifying that every point (x, y) on the graph of an equation represents values x and y that make the equation true.</p>
Assessment Limits / Content Constraints	<ul style="list-style-type: none"> Limited to linear and quadratic equations. May or may not have context; context is preferred. Answer choices may be graphs or explanations.
DOK(s)	1 or 2
Sample Item Stem(s)	<p>Which graph could represent the solution set of $y = x^2 - 4$</p> <p>How do the solutions of an equation relate to the graph of the equation?</p> <p>Which of the following points lie on the graph of the equation.....</p>

Sample Item

An economist has recorded the stock price of Company A after the initial stock sale.

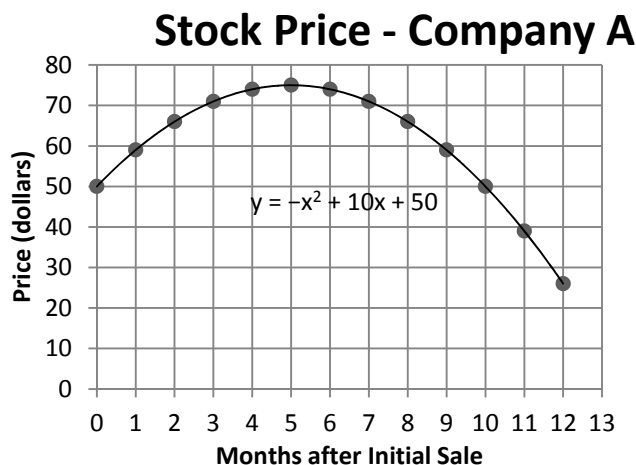

What was the value of the stock price of Company A 10 months after the initial stock sale?
(Correct response: 50)

Domain	A—Algebra
Subdomain	A.REI—Reasoning with Equations and Inequalities
Standard	A-REI.12: Graph the solutions to a linear inequality in two variables as a half-plane (excluding the boundary in the case of a strict inequality), and graph the solution set to a system of linear inequalities in two variables as the intersection of the corresponding half-planes.
Emphasis Level	High
Evidence Statements	<p>The examinee will demonstrate an understanding of graphing the solutions to a linear inequality in two variables as a half-plane (excluding the boundary in the case of a strict inequality).</p> <p>The examinee will demonstrate an understanding of graphing the solution set to a system of linear inequalities in two variables as the intersection of the corresponding half-planes.</p>
Assessment Limits / Content Constraints	<ul style="list-style-type: none"> • May or may not have context; context is preferred. • Answer choices may be graphs or explanations.
DOK(s)	2 or 3
Sample Item Stem(s)	<p>Which graph shows the solution of: $y < 2x + 3$</p> <p>Which graph shows the solution to the system of inequalities.</p>

Sample Item

Which graph represents $2x - 3y \leq 6$?

A.

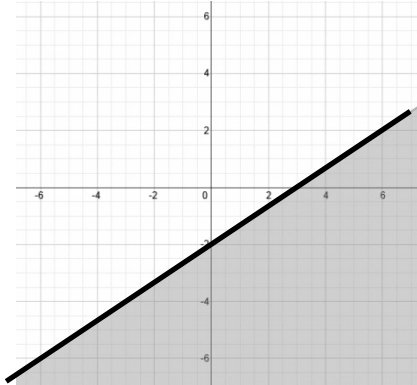

B.

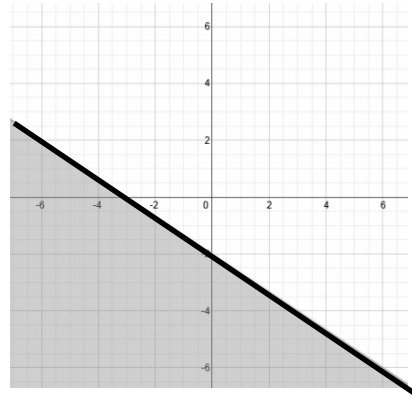

C.

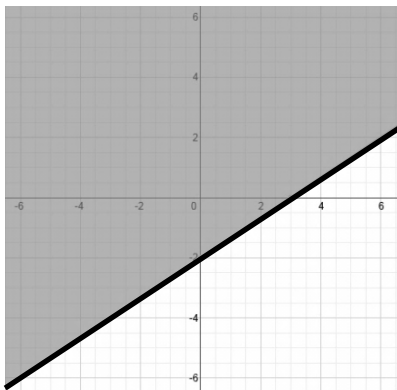

D.

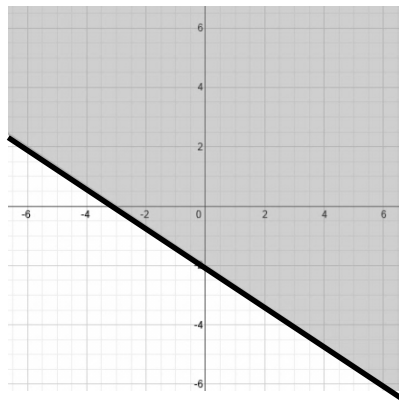

Domain	A—Algebra
Subdomain	A.SSE—Seeing Structure in Expressions
Standard	A.SSE.1: Interpret expressions that represent a quantity in terms of its context.
Emphasis Level	High
Evidence Statements	<p>The examinee will demonstrate an understanding of identifying the different parts of the expression (e.g., degree, term, factor, coefficient, variable, and exponent).</p> <p>The examinee will demonstrate an understanding by explaining the meaning of a part of an expression within the context of a problem.</p> <p>The examinee will demonstrate an understanding of decomposing (rewriting) expressions and making sense of the multiple factors and terms by explaining the meaning of the individual parts.</p>
Assessment Limits / Content Constraints	<ul style="list-style-type: none"> Context is required.
DOK(s)	1 or 2
Sample Item Stem(s)	<p>A mixture contains C liters of cleaning solution in 10 liters of water. Write an expression for the concentration of cleaning solution in the mixture, and explain what each part of the expression represents.</p> <p>A landscaping company uses two different sized trucks to deliver mulch. The first truck can transport x cubic yards, and the second y cubic yards. The first truck makes m trips to a job site, while the second makes n trips.</p> <p>a. What does $x + y$ represent? b. What does $xm + yn$ represent?</p>

Sample Item

The formula $P = 2l + 2w$ can be used to find the perimeter of a rectangle, P , given the length, l , and width, w , of the rectangle.

Which interpretation of $2l + 2w$ is correct?

- A. The perimeter of a rectangle is twice the area of the rectangle.
- B. A rectangle has two sides of length l and two sides of length w . (Correct response)
- C. Half of the perimeter of a rectangle is equal to the length of one side of the rectangle.
- D. To find the perimeter of a rectangle, add all the lengths of the sides of the rectangle and double it.

Domain	A—Algebra
Subdomain	A.SSE—Seeing Structure in Expressions
Standard	A.SSE.2: Use the structure of an expression to identify ways to rewrite it.
Emphasis Level	Low
Evidence Statement	The examinee will demonstrate an understanding of using the structure of expressions to rewrite algebraic expressions in different equivalent forms by using factoring (limited), combining like terms, and using the distributive property and other operations with polynomials.
Assessment Limits / Content Constraints	<ul style="list-style-type: none"> The expressions given should fit common structures so recognition of the structure allows for application of a strategy to be applied.
DOK(s)	2
Sample Item Stem(s)	<p>Find a value for a, a value for b, and a value for c, so that $(3x + 2)(2x - 5) = ax^2 + bx + c$</p> <p>Identify <u>two</u> expressions that are equivalent forms of the expression: $h^4 + 5h^2 + 4$ Select <u>two</u> answers.</p>

Sample Item 1

Which expression is equivalent to $(x^2 + 2x - 3) + (x^2 + 4x)$?

- A. $2x^2 + 6x - 3$ (Correct response)
- B. $x^2 + 3$
- C. $x^2 - 6x - 3$
- D. $2x^2 + 6x + 3$

Sample Item 2

Which expression shows the simplified version of $(a^3 - 2a^2) - (3a^2 - 4a^3)$?

- A. $-2a^3 - 2a^2$
- B. $5a^3 - 5a^2$ (Correct response)
- C. $-3a^3 - a^2$
- D. $2a^3 - 5a^2$

Domain	A—Algebra
Subdomain	A.SSE—Seeing Structure in Expressions
Standard	A.SSE.3: Choose and produce an equivalent form of an expression to reveal and explain properties of the quantity represented by the expression.
Emphasis Level	Low
Evidence Statement	The examinee will demonstrate an understanding that the factored form of a quadratic expression reveals the zeros of the function it defines.
Assessment Limits / Content Constraints	<ul style="list-style-type: none"> Context is not required. Present quadratics in standard form: $ax^2 + bx + c = 0$, where a equals 1.
DOK(s)	1 or 2
Sample Item Stem(s)	<p>What is the meaning of the zeroes of a quadratic function?</p> <p>Select <u>two</u> equations with equivalent zeroes.</p> <p>At what point(s) does the graph of the quadratic function cross the x-axis?</p>

Sample Item

Which expression can be used to find the zeros of $f(x) = x^2 - 2x - 35$?

- A. $(x - 5)(x + 7)$
- B. $(x + 5)(x - 7)$ (Correct response)
- C. $(x - 7)(x - 5)$
- D. $(x + 7)(x + 5)$

Domain	G—Geometry
Subdomain	G.CO—Congruence
Standard	G.CO.1: Know precise definitions of angle, circle, perpendicular line, parallel line, and line segment, based on the undefined notions of point, line, distance along a line, and distance around a circular arc.
Emphasis Level	Medium
Evidence Statement	The examinee will demonstrate an understanding by precisely defining angle, circle, perpendicular line, parallel line, line segment, and other related simple geometric figures.
Assessment Limits / Content Constraints	<ul style="list-style-type: none"> • Create items that assess examinees understanding of definitions in geometry. • Use diagrams when needed to clarify an item. • Can extend definitions to simple geometric figures not listed in the standard. • Limit central angles or arcs to 90°, 180°, and 270°. • No radian measure.
DOK(s)	1 or 2
Sample Item Stem(s)	What is the definition of a circle? Perpendicular lines form what type of angle?

Sample Item

Look at the angle.

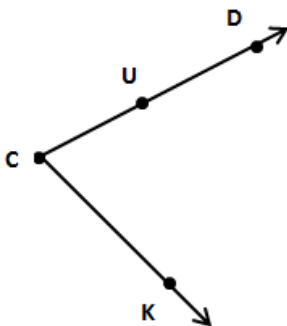

Which name for the angle is not correct?

- A. $\angle DCK$
- B. $\angle KCU$
- C. $\angle CDK$
- D. $\angle UCK$

(Correct response)

Domain	G—Geometry
Subdomain	G.CO—Congruence
Standard	G.CO.6: Use geometric descriptions of rigid motions to transform figures and to predict the effect of a given rigid motion on a given figure; given two figures, use the definition of congruence in terms of rigid motions to decide if they are congruent.
Emphasis Level	Low
Evidence Statement	<p>The examinee will demonstrate an understanding by performing simple rigid transformations (up to three transformations in one item).</p> <p>The examinee will demonstrate an understanding by determining the effect of a rigid transformation upon a figure.</p> <p>The examinee will demonstrate an understanding by determining if two figures are congruent using rigid transformations.</p>
Assessment Limits / Content Constraints	<ul style="list-style-type: none"> • No more than three rigid transformations per item. • Diagrams/figures are required.
DOK(s)	1 or 2
Sample Item Stem(s)	Show the figure reflected across the origin. Which transformation is shown?

Sample Item

Look at the transformation.

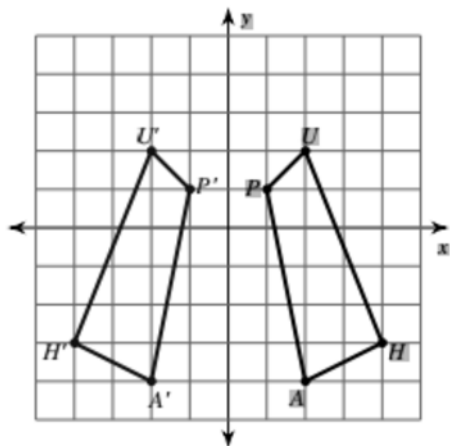

Which rule describes the transformation shown?

- | | |
|--|------------------------------|
| A. Reflection across the y-axis (correct answer) | B. Reflection across $y = x$ |
| C. Rotation 180° about the origin | D. Translation 2 units right |

Domain	G—Geometry
Subdomain	G.GMD—Geometric Measurement and Dimension
Standard	G.GMD.3: Use volume formulas for cylinders, pyramids, cones, and spheres to solve problems.
Emphasis Level	High
Evidence Statement	The examinee will demonstrate an understanding by explaining and using volume formulas to solve problems. The examinee will demonstrate an understanding by calculating the volume of a rectangular prism without being given the formula.
Assessment Limits / Content Constraints	<ul style="list-style-type: none"> • Use diagrams when needed to clarify an item. • Limit bases of pyramids to squares, rectangles, and triangles. • When using triangular bases, the height should be clearly marked.
DOK(s)	2 or 3
Sample Item Stem(s)	Determine the volume of a cylinder with a radius of 3in and a height of 7in. How is the volume of a cone affected by doubling the height? The surface area of a cube is 486 cm^2 . What is the volume of the cube?

Sample Item

Find the volume of the rectangular prism in cubic centimeters.

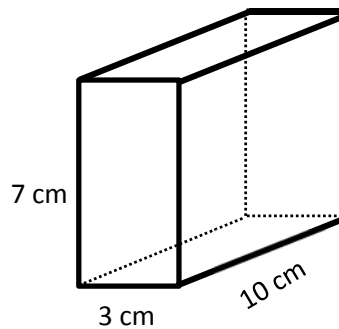

(Correct response: 210 cubic centimeters)

Domain	G—Geometry
Subdomain	G.MG—Modeling with Geometry
Standard	G.MG.1: Use geometric shapes, their measures, and their properties to describe objects (e.g., modeling a tree trunk or a human torso as a cylinder).
Emphasis Level	Low
Evidence Statement	The examinee will demonstrate an understanding by using geometric shapes, measurements, and properties to describe objects.
Assessment Limits / Content Constraints	<ul style="list-style-type: none"> • Relate objects to common, simple geometric figures. • The context used should be familiar to adult learners.
DOK(s)	1, 2, or 3
Sample Item Stem(s)	A log is 12 feet long and has a diameter of approximately 9 inches. Which statement describes the best way to estimate the volume (in cubic feet) of the log?

Sample item

A tennis ball has a diameter of 2.7 inches. Tennis balls come in containers shaped like cylinders. Three tennis balls, stacked one on top of the other, fit exactly into the container. What is the approximate volume of a tennis ball container?

- A. 15.5 cubic inches
- B. 46.4 cubic inches (Correct response)
- C. 61.8 cubic inches
- D. 116.2 cubic inches

Domain	G—Geometry
Subdomain	G.MG—Modeling with Geometry
Standard	G.MG.2: Apply concepts of density based on area and volume in modeling situations (e.g., persons per square mile, BTUs per cubic foot).
Emphasis Level	High
Evidence Statement	The examinee will demonstrate an understanding by applying geometric concepts of density in modeling situations.
Assessment Limits / Content Constraints	<ul style="list-style-type: none"> • Items may use simple geometric formulas. • Diagrams may be included to help clarify the context. • Items should have real-world context. • Items should be limited to three calculations. • Formulas should be provided.
DOK(s)	2 or 3
Sample Item Stem(s)	Given land area and population of cities, classify according to population density. Find the density of an object given a mass and measurements.

Sample Item

A tank in the shape of a right cylinder contains 2,400 liters (l) of gasoline. The weight of the gasoline in the tank is 1,800 kilograms (kg).

What is the density of the gasoline in the tank in kilograms per liter?

(Correct response: 0.75)

Domain	G—Geometry
Subdomain	G.MG—Modeling with Geometry
Standard	7.G.6: Solve real-world and mathematical problems involving area, volume, and surface area of two- and three-dimensional objects composed of triangles, quadrilaterals, polygons, cubes, and right prisms.
Emphasis Level	Low
Evidence Statement	The examinee will demonstrate an understanding by applying geometric methods in modeling situations.
Assessment Limits / Content Constraints	<ul style="list-style-type: none"> • Items may use simple geometric formulas. • Diagrams may be included to help clarify the context. • Items should have real-world context. • Items should be limited to four calculations.
DOK(s)	2 or 3
Sample Item Stem(s)	Select the expression that represents the volume of this solid. How does doubling the width of a figure affect its area? A rectangular prism has a surface area of 388 cm ² . What are the possible dimensions?

Sample Item

A contractor is determining the maximum size of a new concrete patio for a customer.

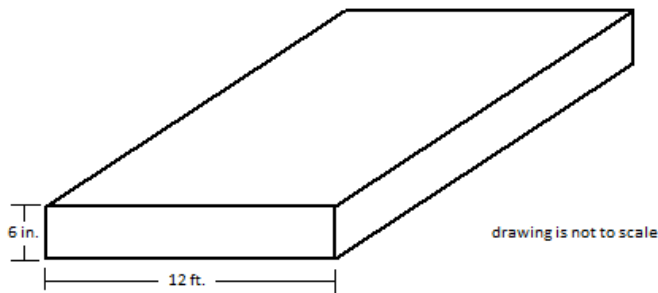

- The patio is to be rectangular.
- The thickness of the patio is to be 6 inches.
- The width of the patio is to be 12 feet.
- The cost of the concrete is \$80.00 per cubic yard.
- The budget for the concrete is \$320.00.

What is the length, in feet, of the largest patio that can be constructed with these conditions?

(Correct response: 18 feet)

Domain	G—Geometry
Subdomain	G.SRT—Similarity, Right Triangles, and Trigonometry
Standard	G.SRT.5: Use congruence and similarity criteria for triangles to solve problems and to prove relationships in geometric figures.
Emphasis Level	Medium
Evidence Statement	The examinee will demonstrate an understanding by using congruence and similarity criteria for triangles to solve problems.
Assessment Limits / Content Constraints	<ul style="list-style-type: none"> • Formal proofs are not being assessed on TASC. • Diagrams or pictures may be used to help clarify an item.
DOK(s)	1, 2, or 3
Sample Item Stem(s)	The triangles below are similar triangles. (diagram) What is the value of x ?

Domain	G—Geometry
Subdomain	G.SRT—Similarity, Right Triangles, and Trigonometry
Standard	8.G.7 Apply the Pythagorean Theorem to determine unknown side lengths in right triangles in real-world and mathematical problems in two and three dimensions.
Emphasis Level	Medium
Evidence Statement	The examinee will demonstrate an understanding by using the Pythagorean Theorem to solve problems involving right triangles.
Assessment Limits / Content Constraints	<ul style="list-style-type: none"> Diagrams or pictures may be used to help clarify an item.
DOK(s)	1, 2, or 3
Sample Item Stem(s)	<p>Determine the length of an unknown side of a right triangle.</p> <p>What is the length of a diagonal of a rectangle given the height and width?</p> <p>A tent is shaped like a square-based pyramid (shown). What is the height of the tent?</p>

Sample Item

Jorge is kicking a hacky sack 10 feet from a flag pole.

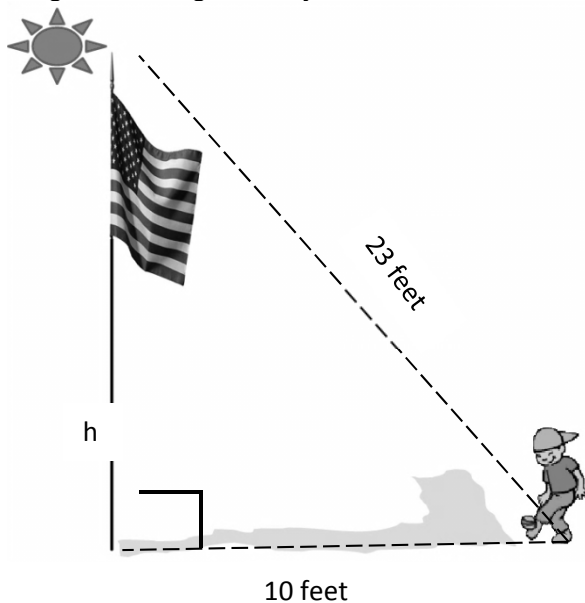

Diagram is not drawn to scale.

How tall is the flag pole to the nearest foot? (Calculator use is permitted for this item)
(Correct response: 21 feet)

Domain	F—Functions
Subdomain	F.BF—Building Functions
Standard	CCR-AE Standard: F.BF.1: Write a function that describes a relationship between two quantities.
Element	F.BF.1a: Determine an explicit expression, a recursive process, or steps for calculation from a context.
Emphasis Level	Low
Evidence Statements	The examinee will demonstrate understanding by writing explicit functions to describe relationships between two quantities from a context.
Assessment Limits / Content Constraints	<ul style="list-style-type: none"> • Construct a function to model a linear relationship between two quantities. • Context is required. • Context must be familiar to an adult. • Input may be a verbal description, a table of values, or a graph. • No recursive functions.
DOK(s)	1 or 2
Sample Item Stem(s)	Which graph represents the function that models changes in Pam’s bank account? Which statement is true about the given function?

Sample Item

An employer is using the function $P(h)$ to calculate the total amount of money required each week to pay his employees.

- The total number of employees is 5.
- Every employee earns \$9.75 per hour.
- Every employee works the same number of hours, h , each week.

Which function models $P(h)$?

- A. $P(h) = 5h$
- B. $P(h) = 9.75h$
- C. $P(h) = (5)9.75h$ (Correct response)
- D. $P(h) = 9.75h + 5$

Domain	F—Functions
Subdomain	F.BF—Building Functions
Standard	F.BF.1: Write a function that describes a relationship between two quantities.
Element	F.BF.1b: Combine standard function types using arithmetic operations. For example, build a function that models the temperature of a cooling body by adding a constant function to a decaying exponential, and relate these functions to the model.
Emphasis Level	Low
Evidence Statements	The examinee will demonstrate an understanding of combining standard function types by using arithmetic operations and relate the new function to a model.
Assessment Limits / Content Constraints	<ul style="list-style-type: none"> • Formulas may be real or created; if the latter, context is required. • Context must be familiar to an adult. • Input may be a verbal description, a table of values, or a graph. • Limited to linear and quadratic functions.
DOK(s)	2
Sample Item Stem(s)	Which expression represents ...

Sample Item

The total cost to build a house can be calculated by multiplying the price per square foot by the number of square feet of the house. Let x be the number of times 25 square feet is added to the size of the house.

- The increase in the price per square foot can be modeled by the expression $30 - 2x$.
- The increase in the number of square feet in the building can be modeled by the expression $200 + 25x$.

Which of these represents the cost to construct the building as the price per square foot decreases and the size of the building increases?

- A. $200 + 23x$
- B. $230 + 23x$
- C. $6000 - 50x^2$
- D. $6000 + 350x - 50x^2$ (Correct response)

Domain	F—Functions
Subdomain	F.BF—Building Functions
Standard	F-BF.2: Write arithmetic and geometric sequences both recursively and with an explicit formula, use them to model situations, and translate between the two forms.
Emphasis Level	Low
Evidence Statements	<p>The examinee will demonstrate an understanding of arithmetic and geometric sequences by using the given terms of the sequence to determine an unknown term of the sequence.</p> <p>The examinee will demonstrate an understanding of arithmetic and geometric sequences by using the given terms to write a rule to find the next term.</p>
Assessment Limits / Content Constraints	<ul style="list-style-type: none"> • The student will be given at least four terms of an arithmetic or geometric sequence (the first term will start with a1) and determine a term within the first 10 terms. • Arithmetic terms should all be integers. • Geometric factors should be $\frac{1}{2}$, 2, or 3.
DOK(s)	1 or 2
Sample Item Stem(s)	<p>What is the 8th term in the sequence?</p> <p>What is the rule to find the next term in the sequence?</p> <p>Which recursive function is a model for a given arithmetic sequence?</p> <p>Which function models the geometric sequence?</p>

Domain	F—Functions
Subdomain	F.IF—Interpreting Functions
Standard	F.IF.1: Understand that a function from one set (called the domain) to another set (called the range) assigns to each element of the domain exactly one element of the range. If f is a function and x is an element of its domain, then $f(x)$ denotes the output of f corresponding to the input x . The graph of f is the graph of the equation $y = f(x)$.
Emphasis Level	High
Evidence Statements	<p>The examinee will demonstrate an understanding that a function from one set (the domain) to another set (the range) assigns to each element of the domain exactly one element of the range (e.g., distinguish between functions and non-functions).</p> <p>The examinee will demonstrate an understanding by recognizing any necessary restriction that needs to be placed on the domain in order for an equation to represent a function. For example, denominators cannot be zero, and any value in a square root radical ($\sqrt{\quad}$) must be positive.</p> <p>The examinee will demonstrate an understanding that the graph of f is the graph of the equation $y = f(x)$.</p>
Assessment Limits / Content Constraints	<ul style="list-style-type: none"> Limit the function representations to graphs/sketches, sets of ordered pairs, function maps, or descriptions of simple functions.
DOK(s)	1 or 2
Sample Item Stem(s)	<p>Which graph represents a function?</p> <p>Which of the following input/output relationships define a function (from data in a table).</p>

Sample Item

Which set of ordered pairs represents a function?

- A. $\{(1, 3), (2, -5), (0, 4), (-1, -3), (2, 5)\}$
- B. $\{(1, 3), (-2, -5), (0, 4), (-1, 3), (2, -5)\}$ (Correct response)
- C. $\{(-1, 3), (-2, -5), (0, 4), (-1, 3), (2, 5)\}$
- D. $\{(1, 3), (-2, -5), (0, 4), (1, -3), (2, -5)\}$

Domain	F—Functions
Subdomain	F.IF—Interpreting Functions
Standard	F.IF.2: Use function notation, evaluate functions for inputs in their domains, and interpret statements that use function notation in terms of a context.
Emphasis Level	High
Evidence Statements	<p>The examinee will demonstrate an understanding by using function notation evaluating inputs.</p> <p>The examinee will demonstrate an understanding by interpreting how function notation is used in a context.</p>
Assessment Limits / Content Constraints	<ul style="list-style-type: none"> • Limit the functions to linear or quadratic. • Distractors should reflect errors in calculation or order of operations.
DOK(s)	1 or 2
Sample Item Stem(s)	What values do the domain and range represent in the function that describes a real-life situation?

Sample Item

If $f(x) = 3x^2 - 2x + 1$, what is $f(-1)$?

- A. -4
- B. 0
- C. 6 (Correct response)
- D. 12

Domain	F—Functions
Subdomain	F.IF—Interpreting Functions
Standard	F.IF.4: For a function that models a relationship between two quantities, interpret key features of graphs and tables in terms of the quantities, and sketch graphs showing key features given a verbal description of the relationship. Key features include the following: intercepts; intervals where the function is increasing, decreasing, positive, or negative; relative maxima and minima; symmetries; end behavior; and periodicity.
Emphasis Level	High
Evidence Statements	The examinee will demonstrate an understanding by interpreting key features of a graph or a table representing a function modeling a relationship between two quantities.
Assessment Limits / Content Constraints	<ul style="list-style-type: none"> • Limit the functions to linear or quadratic. • The equation for the function may be included in the item. • Graphs may be from a context. • Examinees will not be asked to graph the functions.
DOK(s)	1 or 2
Sample Item Stem(s)	<p>What is the maximum of the quadratic function?</p> <p>Which graph represents the function?</p> <p>For which values is the function increasing?</p>

Sample Item

Look at the graph.

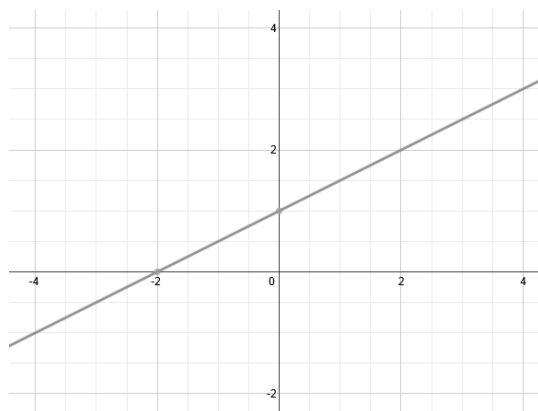

What are the x- and y-intercepts?

- A. (0, -1) and (2, 0)
- B. (0, 1) and (-2, 0) (Correct response)
- C. (-1, 0) and (0, 2)
- D. (1, 0) and (0, -2)

Domain	F—Functions
Subdomain	F.IF—Interpreting Functions
Standard	F.IF.5: Relate the domain of a function to its graph and, where applicable, to the quantitative relationship it describes. For example, if the function $h(n)$ gives the number of person-hours it takes to assemble n engines in a factory, then the positive integers would be an appropriate domain for the function.
Emphasis Level	High
Evidence Statement	The examinee will demonstrate an understanding by relating the domain of a function to its graph and, where applicable, to the quantitative relationship it describes.
Assessment Limits / Content Constraints	<ul style="list-style-type: none"> • Stimulus should include a graph or a description. • Do not ask students to analyze a bounded domain of a polynomial function by providing just the function.
DOK(s)	1 or 2
Sample Item Stem(s)	Which of these functions has a domain of all real numbers? It takes Chris 2 minutes to read one page. What values do the domain and range represent in the function that describes how long it takes Chris to read a given amount of pages?

Sample Item

The graph shows the depth of the snow at Spencer’s Creek, New South Wales, after March 15, 2005.

Spencer’s Creek Snow Depths - 2005

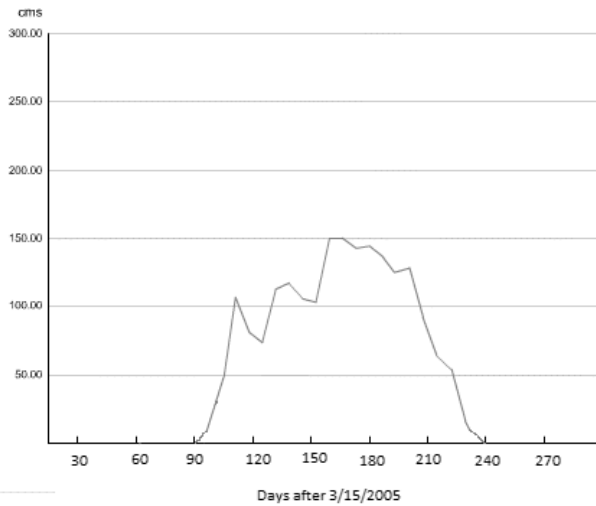

When there is snow on the ground, the function $D(t)$ models the depth of the snow at Spencer’s Creek over time. What is the best description of an appropriate domain for $D(t)$?

- A. all integers between 0 and 150
- B. all integers between 90 and 240
- C. all real numbers between 0 and 150
- D. all real numbers between 90 and 240 (Correct response)

Domain	F—Functions
Subdomain	F.IF—Interpreting Functions
Standard	F.IF.6: Calculate and interpret the average rate of change of a function (presented symbolically or as a table) over a specified interval. Estimate the rate of change from a graph.
Emphasis Level	High
Evidence Statement	The examinee will demonstrate an understanding by calculating and interpreting the average rate of change of a function presented as an equation or as a table. The examinee will demonstrate an understanding by estimating the rate of change of a function from a graph.
Assessment Limits / Content Constraints	<ul style="list-style-type: none"> • Limit to linear and quadratic functions. • May use equations, tables, or graphs. • Context is preferred.
DOK(s)	1, 2, or 3
Sample Item Stem(s)	<p>What is the average rate of change of $f(x) = x^2 + 0.5$ for x-values from 3 to 5?</p> <p>What is the average rate of change shown in the graph?</p> <p>A ball thrown in the air has a height of $h(t) = -16t^2 + 42t + 5$ feet after t seconds. Find the average rate of change of h between 0 and 2 seconds.</p>

Sample Item

The table shows values of a function $f(x)$.

x	$f(x)$
2	-2
3	-1
4	2
5	7
6	14
7	23

Determine the average rate of change of the function from $f(3)$ to $f(6)$.

(Correct response: 5)

Domain	F—Functions
Subdomain	F.IF—Interpreting Functions
Standard	F-IF.7: Graph functions expressed symbolically and show key features of the graph, by hand in simple cases and by using technology for more complicated cases.
Element	F.IF.7a: Graph linear and quadratic functions and show intercepts, maxima, and minima.
Emphasis Level	High
Evidence Statements	<p>The examinee will demonstrate an understanding by identifying the graph of a given function.</p> <p>The examinee will demonstrate an understanding by identifying the key features (intercepts, maximum, and minimum) on a graph of a function.</p>
Assessment Limits / Content Constraints	<ul style="list-style-type: none"> • Limit the functions to linear or quadratic. • Stem must ask about the minimum, maximum, or intercepts of the function.
DOK(s)	1 or 2
Sample Item Stem(s)	<p>Which graph represents ...</p> <p>What is the maximum value of the function shown in the graph?</p> <p>What are the zeroes of the function shown in the graph?</p>

Sample Item

The function $f(x) = -12x + 60$ is used to model the amount of fuel in the fuel tank of a truck as it travels at a constant rate.

- $f(x)$ is the amount of fuel in the tank in gallons.
- x is the number of hours after the truck begins the trip.

Which sketch of the graph of $f(x)$ correctly shows the x- and y-intercepts?

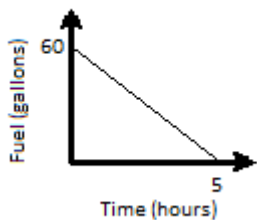

A.

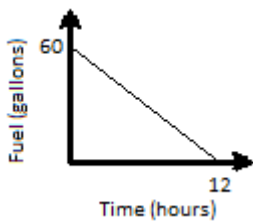

B.

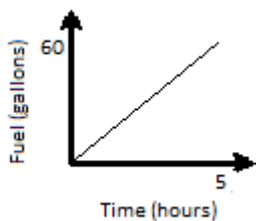

C.

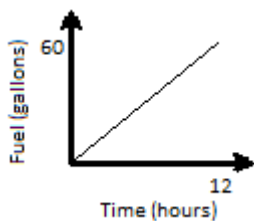

D.

Domain	F—Functions
Subdomain	F.IF—Interpreting Functions
Standard	F-IF.7: Graph functions expressed symbolically and show key features of the graph, by hand in simple cases and by using technology for more complicated cases.
Element	F-IF.7.b: Graph square root, cube root, and piecewise-defined functions, including step functions and absolute value functions.
Emphasis Level	Low
Evidence Statement	The examinee will demonstrate an understanding by graphing square, cube root, and absolute value functions and by identifying key features of those graphs.
Assessment Limits / Content Constraints	<ul style="list-style-type: none"> Limit to simple square root, cube root, or absolute value functions.
DOK(s)	1 or 2
Sample Item Stem(s)	Which function is represented by the graph?

Sample item

What are the x - and y -intercepts of the function $y = \sqrt{x + 4} - 1$?

- A. (3, 0) and (0, -1)
- B. (1, 0) and (3, 0)
- C. (-3, 0) and (0, 1) (Correct response)
- D. (-1, 0) and (-3, 0)

Domain	F—Functions
Subdomain	F.IF—Interpreting Functions
Standard	F-IF.7: Graph functions expressed symbolically and show key features of the graph, by hand in simple cases and by using technology for more complicated cases.
Element	F-IF.7.c: Graph polynomial functions, identifying zeros when suitable factorizations are available, and showing end behavior.
Emphasis Level	Low
Evidence Statement	The examinee will demonstrate an understanding by identifying graphs of polynomial functions. The examinee will demonstrate an understanding by identifying zeros of polynomial functions using factorization, and show end behavior.
Assessment Limits / Content Constraints	<ul style="list-style-type: none"> Limit to linear or quadratic functions.
DOK(s)	1, 2, or 3
Sample Item Stem(s)	Which graph shows a quadratic function with zeroes at What happens to the function when the values of x are very large?

Sample item

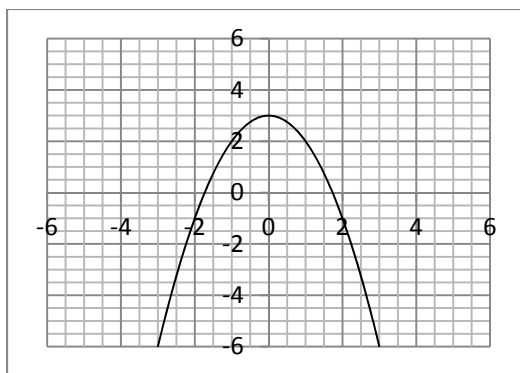

Which equation best matches the graph shown?

- A. $-x^2 + 3$ (Correct response)
- B. $x^2 + 3$
- C. $-x^3 + 2$
- D. $x^3 + 2$

Domain	F—Functions
Subdomain	F.IF—Interpreting Functions
Standard	CCR-AE Standard F.IF.8: Write a function defined by an expression in different but equivalent forms to reveal and explain different properties of the function.
Element	F.IF.8a: Use the process of factoring and completing the square in a quadratic function to show zeros, extreme values, and symmetry of the graph, and interpret these in terms of a context.
Emphasis Level	Medium
Evidence Statement	The examinee will demonstrate an understanding by writing a quadratic function defined by an expression in equivalent factored form and completing the square form to reveal zeros, extreme values, and symmetry of the graph, and by interpreting these in terms of a context.
Assessment Limits / Content Constraints	<ul style="list-style-type: none"> • Use factorable quadratics in the form $ax^2 + bx + c$. • Focus on cases in which $a = 1$. If $a \neq 1$, then the expression should be able to be factored into the form $a(x-h)(x-k)$. • a, b, and c may be numbers with absolute values less than 20. • Context familiar to adult learners is required.
DOK(s)	1 or 2
Sample Item Stem(s)	The height of a water-powered rocket at time t seconds is given by $h(t) = -6t^2 + 96t$. About how many seconds will it take for the rocket to be 64 feet high? Solve $3x - 6x^2 = -9$

Sample item

Sara is practicing her diving. Her height (h) above the water, in meters, is given by the equation $h(t) = -5t^2 + 10t + 15$, t seconds after Sara leaves the diving board. How many seconds does it take Sara to hit the water?

(Correct response: 3 seconds)

Domain	F—Functions
Subdomain	F.IF—Interpreting Functions
Standard	CCR-AE Standard: F.IF.8: Write a function defined by an expression in different but equivalent forms to reveal and explain different properties of the function.
Element	F.IF.8b: Use the properties of exponents to interpret expressions for exponential functions. For example, identify percent rate of change in functions such as $y = (1.02)^t$, $y = (0.97)^t$, $y = (1.01)^{12t}$, and $y = (1.2)^t/10$, and classify them as representing exponential growth or decay.
Emphasis Level	High
Evidence Statement	<p>The examinee will demonstrate an understanding by writing an exponential function defined by an expression in an equivalent form.</p> <p>The examinee will demonstrate an understanding by using the properties of exponents to reveal and explain different properties of the function.</p> <p>The examinee will demonstrate an understanding by classifying exponential functions as representing exponential growth or decay.</p>
Assessment Limits / Content Constraints	<ul style="list-style-type: none"> Context familiar to adult learners is required. Use integer exponents.
DOK(s)	1, 2, or 3
Sample Item Stem(s)	Does the function represent growth or decay? At what rate? Adam buys a new SUV for \$32,000. It depreciates at a rate of 12% each year. What will the SUV be worth in 8 years?

Sample Item

Which three equations represent exponential decay? Select all three (3) correct answers.

A. $y = (1.02)^x$

B. $y = \left(\frac{1}{2}\right)^x$ (Correct response)

C. $y = (0.98)^{5x}$ (Correct response)

D. $y = \left(\frac{3}{2}\right)^{4x}$

E. $y = 4\left(\frac{7}{8}\right)^{2x}$ (Correct response)

Domain	F—Functions
Subdomain	F.IF—Interpreting Functions
Standard	F.IF.9: Compare properties of two functions each represented in a different way (algebraically, graphically, numerically in tables, or by verbal descriptions). For example, given a graph of one quadratic function and an algebraic expression for another, say which has the larger maximum.
Emphasis Level	Low
Evidence Statement	The examinee will demonstrate an understanding by comparing properties of two functions, each represented in a different way (e.g., as equations, functions, tables, graphs, or written descriptions).
Assessment Limits / Content Constraints	<ul style="list-style-type: none"> • Limit functions to linear and quadratics. • Use a combination of functions written algebraically, graphically, numerically in tables, or by verbal description.
DOK(s)	2
Sample Item Stem(s)	Given a graph of a quadratic function and an equation of another, select which statement is true. Which of the following functions (represented in different ways) has the greatest slope?

Sample Item

Consider the table of values for the function $f(x)$ and $g(x)$ as shown in the graph.

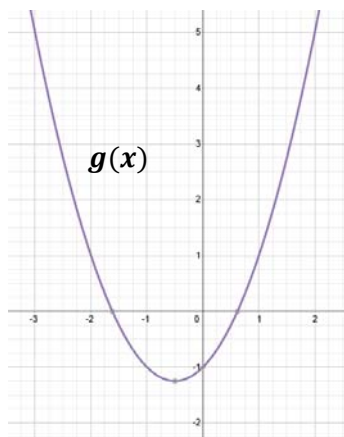

x	$f(x)$
-1	7
0	2
1	-1
2	-2
3	-1

Which function has the smallest minimum?

- A. $f(x)$ has the smallest minimum, located at $(-2, 2)$.
- B. $g(x)$ has the smallest minimum, located at $(-0.5, -1.25)$.
- C. $f(x)$ has the smallest minimum, located at $(2, -2)$.
- D. $g(x)$ has the smallest minimum, located at $(-1.25, -0.5)$.

(Correct response)

Domain	F—Functions
Subdomain	F.LE—Linear, Quadratic, and Exponential Models
Standard	F.LE.1: Distinguish between situations that can be modeled with linear functions and with exponential functions.
Element	F.LE.1a: Prove that linear functions grow by equal differences over equal intervals and that exponential functions grow by equal factors over equal intervals.
Emphasis Level	Medium
Evidence Statements (or PLDs)	<p>The examinee will demonstrate an understanding by recognizing that linear functions change at the same rate over time.</p> <p>The examinee will demonstrate an understanding by recognizing that exponential functions grow by the same factor over time.</p>
Assessment Limits / Content Constraints	<ul style="list-style-type: none"> Context is recommended. The function should be expressed as an equation, table of values, graph, or in verbal context. Exponential functions should be simple, such as $y = 2^x$ or $y = \left(\frac{1}{2}\right)^x$.
DOK(s)	1, 2, or 3
Sample Item Stem(s)	Which table/graph/equation displays a linear/exponential function? Which description matches the function?

Sample Item

Which table displays an exponential function?

A.

x	1	2	3	4	5
y	2	4	6	8	10

B.

x	1	2	3	4	5
y	4	16	32	48	64

C.

x	1	2	3	4	5
y	3	6	9	12	15

D.

x	1	2	3	4	5
y	2	4	8	16	32

(Correct response)

Domain	F—Functions
Subdomain	F.LE—Linear, Quadratic, and Exponential Models
Standard	CCR-AE Standard: F.LE.1: Distinguish between situations that can be modeled with linear functions and with exponential functions.
Element	F.LE.1b: Recognize situations in which one quantity changes at a constant rate per unit interval relative to another.
Emphasis Level	Medium
Evidence Statements	<p>Given a contextual situation, the examinee will demonstrate an understanding by recognizing that a situation has a linear pattern of change.</p> <p>The examinee will demonstrate an understanding by showing that linear functions change at the same rate over time.</p> <p>The examinee will demonstrate an understanding by describing situations where one quantity changes at a constant rate per unit interval as compared to another quantity.</p>
Assessment Limits / Content Constraints	<ul style="list-style-type: none"> • Context is recommended. • Functions should be expressed as an equation, a verbal context, a table of values, or a graph.
DOK(s)	1, 2, or 3
Sample Item Stem(s)	Which statement describes how we know this situation can be modeled by a linear function?

Sample Item

A technician is testing the voltage drop of two batteries. The data are shown in the table.

Time (hrs)	Voltage in Battery A	Voltage in Battery B
0	12	12
2	10	10
4	8	6
6	6	2

Which battery shows a linear relationship between voltage and time, and why?

- A. Battery A, because the rate of change in the voltage is a constant -1 volt per hour (Correct response)
- B. Battery A, because the rate of change in the voltage is a constant -2 volts per hour
- C. Battery B, because the rate of change in the voltage is a constant -1 volt per hour
- D. Battery B, because the rate of change in the voltage is a constant -2 volts per hour

Domain	F—Functions
Subdomain	F.LE—Linear, Quadratic, and Exponential Models
Standard	CCR-AE Standard: F.LE.1: Distinguish between situations that can be modeled with linear functions and with exponential functions.
Element	F.LE.1c: Recognize situations in which a quantity grows or decays by a constant percent rate per unit interval relative to another.
Emphasis Level	Low
Evidence Statements (or PLDs)	<p>Given a contextual situation, the examinee will demonstrate an understanding by describing whether the situation in question has an exponential pattern of change.</p> <p>The examinee will demonstrate an understanding by showing that exponential functions change by equal factors over time.</p> <p>The examinee will demonstrate an understanding by describing situations where one quantity changes at a constant percent rate per unit interval as compared to another.</p>
Assessment Limits / Content Constraints	<ul style="list-style-type: none"> Context is required. Functions should be expressed as an equation, a verbal context, a table of values, or a graph. Exponential functions should be simple, such as $y = 2^x$ or $y = \left(\frac{1}{2}\right)^x$.
DOK(s)	1 or 2
Sample Item Stem(s)	Which statement describes how we know this situation can be modeled by an exponential function?

Sample Item

The table shows the increase in the balance of an investment account after the year 2000.

Year	Balance
2000	\$1,000.00
2001	\$1,050.00
2002	\$1,102.50
2003	\$1,157.63

Which of these is not true?

- The balance in the account is growing every year.
- The balance in the account is increasing by 5% each year.
- The rate of growth in this account is about the same for every year.
- The same amount of money is being added to the account every year. (Correct response)

Domain	F—Functions
Subdomain	F.LE—Linear, Quadratic, and Exponential Models
Standard	F.LE.2: Construct linear and exponential functions, including arithmetic and geometric sequences, given a graph, a description of a relationship, or two input-output pairs (include reading these from a table).
Emphasis Level	Medium
Evidence Statement	The examinee will demonstrate an understanding by constructing linear and exponential functions from a graph, a description of a relationship, or a table.
Assessment Limits / Content Constraints	<ul style="list-style-type: none"> Exponential functions should be simple, such as $y = 2^x$ or $y = \left(\frac{1}{2}\right)^x$. The stimulus could be a graph, a table of values, or a verbal description. Use adult contexts when appropriate. Do not include arithmetic and geometric sequences.
DOK(s)	1 or 2
Sample Item Stem(s)	Which function describes the relationship shown in the graph/table? Which function represents this situation?

Sample item

A company uses a graph to show the costs for shipping an envelope. For example, an envelope that weighs 5 ounces (oz.) costs \$4.00 to ship.



If $C(x)$ is the cost to ship an envelope that weighs x ounces (oz.), which function can be used to calculate the costs for shipping?

- A. $C(x) = 0.2x$
- B. $C(x) = 0.8x$
- C. $C(x) = 0.2x + 3$ (Correct response)
- D. $C(x) = 0.8x + 3$

Domain	F—Functions
Subdomain	F.LE—Linear, Quadratic, and Exponential Models
Standard	F.LE.3: Observe using graphs and tables that a quantity increasing exponentially eventually exceeds a quantity increasing linearly, quadratically, or (more generally) as a polynomial function.
Emphasis Level	Medium
Evidence Statement	The examinee will demonstrate an understanding by comparing the rates of increase between linear, exponential, and quadratic functions.
Assessment Limits / Content Constraints	<ul style="list-style-type: none"> • May compare an exponential function to a linear or quadratic function. • Exponential functions should be simple, such as $y = 2^x$ or $y = \left(\frac{1}{2}\right)^x$. • The stimulus must include a graph or a table of values. • Use adult contexts when appropriate.
DOK(s)	1 or 2
Sample Item Stem(s)	Which function will have the greatest value when $x = 10$? For which values of x will $f(x)$ be greater than $g(x)$?

Sample Item

Andrea is comparing two options for investing an initial amount of \$5,000 in an investment account.

Investment option 1: An additional \$52 is added to the investment account every month.
Investment option 2: An amount equal to 1% of the current value of the account is added to the account every month.

As the amount of money in the account grows over time, which investment option will make the most money for Andrea? How many months will pass before the better investment option exceeds the other option?

- Investment option 1 is better; it will always exceed option 2.
- Investment option 1 is better; it will exceed option 2 after 9 months.
- Investment option 2 is better; it will always exceed option 1.
- Investment option 2 is better; it will exceed option 1 after 9 months. (Correct response)

Domain	F—Functions
Subdomain	F.LE—Linear, Quadratic, and Exponential Models
Standard	F.LE.5: Interpret the parameters in a linear, quadratic, or exponential function in terms of a context.
Emphasis Level	Medium
Evidence Statements (or PLDs)	The examinee will demonstrate an understanding by interpreting the parameters of linear, and exponential functions from a context.
Assessment Limits / Content Constraints	<ul style="list-style-type: none"> • Limit exponential functions to $y = a(b^x)$. • Provide the functions in every case so that examinees can see the equation. • Other stimuli might be a graph, a table of values, or a verbal description. • Use adult contexts when appropriate. • For linear functions, ask about slope/rate of change and y-intercept/initial value, and provide the meaning of x or $f(x)$. • For exponential functions, ask about percent rate of change and y-intercept/initial value, and provide the meaning of x or $f(x)$.
DOK(s)	1 or 2
Sample Item Stem(s)	Based on the equation, what is the starting value? What is the rate of change/percent rate of change of the function?

Sample Item

A company uses the function $C(x) = 0.2x + 3$ to calculate shipping costs.

- $C(x)$ is the total cost (in dollars) to ship an envelope.
- x is the weight of the envelope in ounces.

What do the values 0.2 and 3 represent in the function?

- The cost to ship a 3-ounce envelope is \$0.20.
- The cost to ship a 0.2-ounce envelope is \$3.00.
- The cost to ship an envelope is \$0.20 plus \$3.00 per ounce.
- The cost to ship an envelope is \$3.00 plus \$0.20 per ounce.

(Correct response)

Domain	N—Number and Quantity
Subdomain	N.Q—Quantities
Standard	N-Q.1: Use units as a way to understand problems and to guide the solution of multi-step problems; choose and interpret units consistently in formulas; choose and interpret the scale and the origin in graphs and data displays.
Emphasis Level	High
Evidence Statements	The examinee will demonstrate an understanding by reasoning quantitatively and using units to solve problems. The examinee will demonstrate an understanding by choosing and interpreting units and scale in formulas and graphs.
Assessment Limits / Content Constraints	<ul style="list-style-type: none"> • Items can be written to standard 7.RP.A: analyze proportional relationships and use them to solve real-world and mathematical problems. • Context is required. • Computation can be involved, but distractors should be focused on misconceptions involving units. • Interpret units in the context of the problem. • Use word problems in which quantities are given in different units, which must be converted to make sense of the problem. • When solving a multi-step problem, use units to evaluate the appropriateness of the solution. • Choose and interpret both the scale and the origin in graphs and data displays, including line graphs, multi-line graphs, scatter plots, and multi-bar graphs.
DOK(s)	1, 2, or 3
Sample Item Stem(s)	What is the density/speed/rate

Sample Item
(Calculator use is permitted for this item.)

The density of salt is 80 pounds per cubic foot (lb/ft³).

- 1 pound (lb) is approximately 0.4536 kilogram (kg).
- 1 cubic foot (ft³) is approximately 0.0283 cubic meter (m³).

What is the approximate density of salt in kilograms per cubic meter (kg/m³)?

- A. 36 kg/m³
- B. 176 kg/m³
- C. 1282 kg/m³ (Correct response)
- D. 2827 kg/m³

Domain	N—Number and Quantity
Subdomain	N.Q—Quantities
Standard	N-Q.3: Choose a level of accuracy appropriate to limitations on measurement when reporting quantities.
Emphasis Level	Medium
Evidence Statements	The examinee will demonstrate an understanding by choosing units and methods that provide an appropriate level of accuracy in situations and contexts.
Assessment Limits / Content Constraints	<ul style="list-style-type: none"> Context is required. Computation can be involved, but distractors should be focused on degree of accuracy. Determine the accuracy of values, based on their limitations in the context of the situation. The margin of error and tolerance limit varies according to the measurement tool used and context.
DOK(s)	1, 2, or 3
Sample Item Stem(s)	What is the <u>most</u> appropriate estimate of ... Explain why a prediction of is inappropriate in this situation. How many.... in this situation.

Sample Item

One gallon of paint covers 375 square feet of wall space. How many whole gallons of paint are required for 2,350 square feet?

- A. 5
 - B. 6
 - C. 7
 - D. 8
- (Correct response)

Domain	N—Number and Quantity
Subdomain	N.RN—The Real Number System
Standard	N-RN.2: Rewrite expressions involving radicals and rational exponents using the properties of exponents.
Emphasis Level	High
Evidence Statements	The examinee will demonstrate an understanding by rewriting expressions involving multiplication and division of terms with integer exponents.
Assessment Limits / Content Constraints	<ul style="list-style-type: none"> • Items can be written to standard 8.EE.1: Know and apply the properties of integer exponents to generate equivalent numerical expressions. For example, $3^2 \cdot 3^{-5} = 3^{-3} = \frac{1}{27}$. • Radicals are limited to square roots. • Exponents are limited to integer exponents. • Computation may include concepts other than using the properties of exponents (e.g., adding like terms), but distractors should reflect errors in applying laws of exponents.
DOK(s)	1 or 2
Sample Item Stem(s)	How is this number written as an exponential expression with a base of 5? What is the standard form of this exponential expression?

Sample Item

What is the value of $\sqrt{5^4}$?

- A. $\frac{1}{625}$
- B. $\frac{1}{25}$
- C. 25 (Correct response)
- D. 625

Domain	N—Number and Quantity
Subdomain	N.RN—The Real Number System
Standard	N-RN.3: Explain why the sum or product of rational numbers is rational; that the sum of a rational number and an irrational number is irrational; and that the product of a nonzero rational number and an irrational number is irrational.
Emphasis Level	Low
Evidence Statements	The examinee will demonstrate a knowledge of classifying expressions with rational and irrational numbers.
Assessment Limits / Content Constraints	<ul style="list-style-type: none"> • Items will only have a single operation and the operation will only be addition or multiplication. • Irrational numbers should be easily recognizable (i.e. π or e) or the square root of 2, 3, 5, 6, 7, or 8.
DOK(s)	1 or 2
Sample Item Stem(s)	Which expression represents a rational/irrational number? Which number can we multiply $\sqrt{2}$ by to get a rational number?

Domain	S—Statistics & Probability
Subdomain	S.CP—Conditional Probability and Rules of Probability
Standard	7.SP.8b: Represent sample spaces for compound events using methods such as organized lists, tables, and tree diagrams. For an event described in everyday language (e.g., “rolling double sixes”), identify the outcomes in the sample space which compose the event.
Emphasis Level	Low
Evidence Statement	The examinee will demonstrate an understanding by using probability and sample spaces to describe and interpret events.
Assessment Limits / Content Constraints	<ul style="list-style-type: none"> • Include items concerning subsets and the concepts of union, intersection, or complements of subsets. • Tables or Venn diagrams would be appropriate here. • Do not assess examinees’ ability to remember or use the formulas for conditional probability. • Determine whether two events are independent, and justify the conclusion. • Context is required.
DOK(s)	1, 2, or 3
Sample Item Stem(s)	How many possible outcomes are there... Given the sample space listed, how many ways are there to get...

Sample Item

How many possible outcomes are there if two six-sided number cubes are tossed?

(Correct response: 36)

Domain	S—Statistics & Probability
Subdomain	S.CP—Conditional Probability and Rules of Probability
Standard	7.SP.7a: Develop a uniform probability model by assigning equal probability to all outcomes, and use the model to determine probabilities of events. <i>For example, if a student is selected at random from a class, find the probability that Jane will be selected and the probability that a girl will be selected.</i>
Emphasis Level	Low
Evidence Statement	The examinee will demonstrate an understanding by recognizing and explaining probabilities, using everyday language and situations.
Assessment Limits / Content Constraints	<ul style="list-style-type: none"> • Tables or diagrams should be used in every item. • Context is required.
DOK(s)	1, 2, or 3
Sample Item Stem(s)	There are 8 boys and 6 girls in a class. When a student is selected at random, what is the probability that the student is a girl? Based on the spinner shown, what is the probability of the spinner landing on blue?

Domain	S—Statistics & Probability
Subdomain	S.CP—Conditional Probability and Rules of Probability
Standard	7.SP.8a: Understand that, just as with simple events, the probability of a compound event is the fraction of outcomes in the sample space for which the compound event occurs. (Aligns closely to S.CP.7.)
Emphasis Level	Low
Evidence Statement	The examinee will demonstrate an understanding by finding compound probabilities and interpreting answers that arise.
Assessment Limits / Content Constraints	<ul style="list-style-type: none"> • Compound events can be two separate simple events (independent) • Compound events can be basic related events (“no replacement”), but in these cases limit sample space so that problem can be solved by creating lists or diagrams
DOK(s)	1 or 2
Sample Item Stem(s)	<p>What is the probability of getting heads and rolling a 5?</p> <p>When two students are selected at random, what is the probability that one is a man and that the other is a woman?</p>

Sample Item 1

Luke polled the students in his English class to see whether they read a book or watched TV the night before. He put the results in this table.

	Read a book	Did not read a book
Watched TV	12	8
Did not watch TV	7	3

What is the probability that a student who read a book did not watch TV the night before?

(Correct response: 7/19)

Sample Item 2

Look at the Venn Diagram.

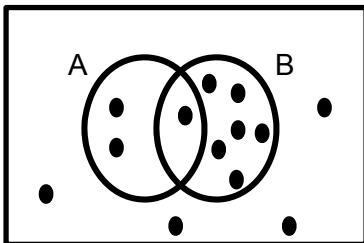

What is the probability of Event A or Event B occurring?

(Correct response: $\frac{9}{13}$)

Domain	S—Statistics & Probability
Subdomain	S.IC Making Inferences and Justifying Conclusions
Standard	7.SP.1: Understand that statistics can be used to gain information about a population by examining a sample of the population; generalizations about a population from a sample are valid only if the sample is representative of that population. Understand that random sampling tends to produce representative samples and support valid inferences.
Emphasis Level	Medium
Evidence Statement	The examinee will demonstrate an understanding that statistics involves drawing conclusions about a population based on the results obtained from a random sample of the population.
Assessment Limits / Content Constraints	<ul style="list-style-type: none"> • Draw on different kinds of sampling methods. • Context is required. • Do not use Goodness of Fit tests. • Possible data-generating processes include (but are not limited to) flipping coins, spinning spinners, rolling a number cube, and using simulations with random number generators. • The examinee can explain how randomization relates to sample surveys, experiments, and observational studies. • Context familiar to adults is required.
DOK(s)	1 or 2
Sample Item Stem(s)	Which sample will best represent the population? Which conclusion can be drawn from this sample?

Sample Item 1

From a group of 12 employees, 3 workers are to be randomly selected to serve on a safety advisory panel.

Which sampling method is most likely to result in a random sample?

- Consult with the accounting office, and then select the first three names on the payroll.
- Send the employees home, and then select the first three who come to work in the morning.
- Place the names of the employees in a hat, mix them thoroughly, and select three names from the mix. (Correct response)
- Ask the group for volunteers, create a list, and alphabetically select the first three workers who volunteer.

Sample Item 2

The illustration shows a game in which a person spins the arrow and wins one of six prizes based on where the arrow stops. Each segment of the circle in the game is the same size.

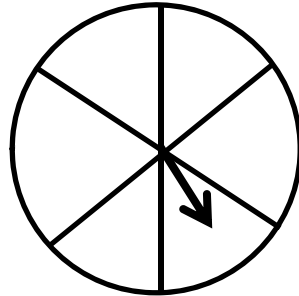

Which statement illustrates that winning any one of the prizes is the result of random selection?

- A. During the first six spins of the game, each prize will be awarded.
- B. Over time, one of the six prizes will be awarded more than the others.
- C. If one prize is awarded six times in a row, it will not be awarded on the next spin.
- D. As more people play the game, the same number of each prize will be awarded.
 (Correct response)

Sample Item 3

A medical researcher is selecting participants for a study on the effects of a drug on memory. She is separating the participants into two groups. The first group will receive the drug and the second group will receive a placebo.

Which of these is a good method for ensuring a random selection of participants in each group?

- A. The participants should be selected based on their age.
- B. The group selections should be made by selecting names out of a hat. (Correct response)
- C. The men should be in one group and the women should be in the other.
- D. The participants should be allowed to choose which group they want to be in.

Domain	S—Statistics & Probability
Subdomain	S.ID—Interpreting Categorical and Quantitative Data
Standard	S.ID.1: Represent data with plots on a real number line (dot plots, histograms, and box plots).
Emphasis Level	Medium
Evidence Statement	The examinee will demonstrate an understanding by representing data on the real number line with a dot plot, histogram, or box plot.
Assessment Limits / Content Constraints	<ul style="list-style-type: none"> Context is required. Diagrams or graphs are required.
DOK(s)	1 or 2
Sample Item Stem(s)	Which dot plot/histogram/box plot represents this situation?

Sample Item

A movie theater recorded the number of tickets sold for two movies each day during one week. Box plots of the data are shown.

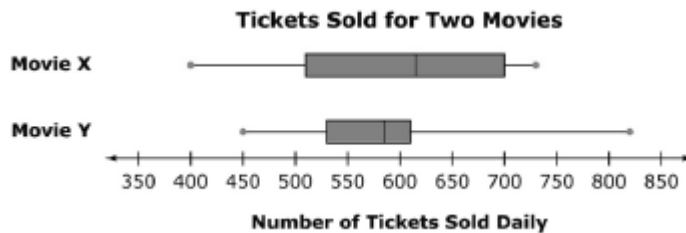

Based on the box plots, which of these statements is not true?

- On at least one day, Movie X sold fewer tickets than Movie Y.
 - On at least one day, more tickets were sold for Movie Y than for Movie X.
 - The median number of tickets sold daily is greater for Movie X than for Movie Y.
 - There is a greater range in the number of tickets sold daily for Movie X than for Movie Y.
- (Correct response)

Domain	S—Statistics & Probability
Subdomain	S.ID—Interpreting Categorical and Quantitative Data
Standard	S.ID.3: Interpret differences in shape, center, and spread in the context of the data sets, accounting for possible effects of extreme data points (outliers).
Emphasis Level	Medium
Evidence Statement	The examinee will demonstrate an understanding by interpreting the differences in shape, center, and spread in the context of data sets.
Assessment Limits / Content Constraints	<ul style="list-style-type: none"> • Context is required. • Diagrams or graphs are required. • Use two data sets with no more than 20 data points. • Use dot plot, histogram, or box plot.
DOK(s)	1 or 2
Sample Item Stem(s)	Which data set has the greatest variance? Which pair of data sets have the same median/mean but a different range/interquartile range?

Sample Item 1

A car dealership has 46 cars for sale. The least expensive car costs \$10,959. The most expensive car costs \$21,250. The mean sales price for the 46 cars is \$17,450. Another car, priced at \$32,675, is added to the dealership's inventory.

Which two statistical measures will not necessarily increase? Select two responses.

- A. mean
- B. median (Correct response)
- C. mode (Correct response)
- D. range
- E. standard deviation

Sample Item 2

The frequency distributions of two data sets are shown in the dot plots.

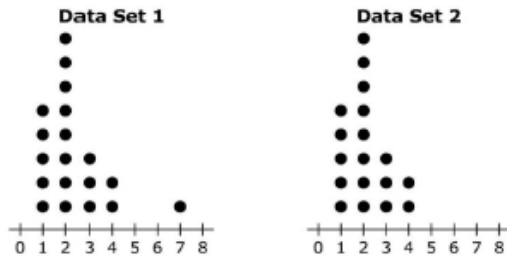

Which statement is true for these data sets?

- A. The mean of the data sets is equal, and the median of Set 1 is greater than Set 2.
- B. The mean of the data sets is equal, and the median of Set 2 is greater than Set 1.
- C. The median of the data sets is equal, and the mean of Set 1 is greater than Set 2.
 (Correct response)
- D. The median of the data sets is equal, and the mean of Set 2 is greater than Set 1.

Domain	S—Statistics & Probability
Subdomain	S.ID—Interpreting Categorical and Quantitative Data
Standard	S.ID.5: Summarize categorical data for two categories in two-way frequency tables. Interpret relative frequencies in the context of the data (including joint, marginal, and conditional relative frequencies). Recognize possible associations and trends in the data.
Emphasis Level	Medium
Evidence Statements	<p>The examinee will demonstrate an understanding by reading and interpreting data displayed in a two-way table.</p> <p>The examinee will demonstrate an understanding by identifying a summary of data displayed in a two-way frequency table.</p> <p>The examinee will demonstrate an understanding by describing patterns observed in the data.</p>
Assessment Limits / Content Constraints	<ul style="list-style-type: none"> • Use tables, graphs, or diagrams in items. • Context is required.
DOK(s)	1, 2, or 3
Sample Item Stem(s)	<p>What is the relative frequency of ...</p> <p>What is the relationship between adults who liked the movie and children who liked the movie?</p>

Sample Item

The table shows the number of students in an area who use corrective eyewear.

Age	Uses only prescription glasses	Uses contact lenses
Less than 10	13	2
10–13	33	6
14–17	38	18

To the nearest hundredth, what is the relative frequency of students who use only prescription glasses?

(Correct response: 0.76)

Domain	S—Statistics & Probability
Subdomain	S.ID—Interpreting Categorical and Quantitative Data
Standard	S.ID.7: Interpret the slope (rate of change) and the intercept (constant term) of a linear model in the context of the data.
Emphasis Level	Medium
Evidence Statement	The examinee will demonstrate an understanding by explaining the meaning of slope and y-intercept in terms of the units stated in the data and context of the situation.
Assessment Limits / Content Constraints	<ul style="list-style-type: none"> Context is required. Stimulus should be a scatter-plot with a trend line.
DOK(s)	2 or 3
Sample Item Stem(s)	What is the slope/y-intercept of the trend line? What does the slope/y-intercept of the trend line mean in the context of this situation?

Sample Item

As shown in the table, the trend line, $y = -0.04x + 3.77$, is a linear model of the price of gasoline for this time period.

- x is the month after January 2013.
- y is the monthly average price of a gallon of gasoline in dollars.

Price of Gasoline, 2013

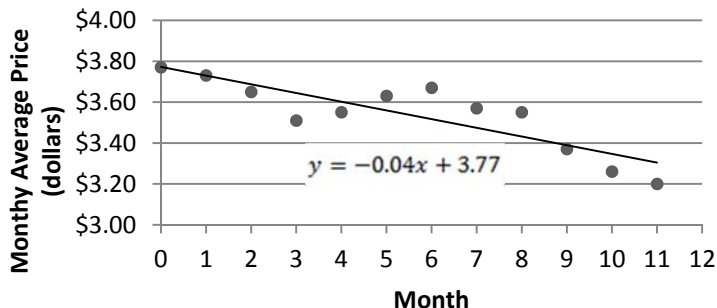

What does the value 3.77 mean in the context of this graph?

- The price of gasoline averaged \$3.77 in 2013.
- The price of gasoline decreased about \$3.77 during 2013.
- The price of gasoline was about \$3.77 at the beginning of 2013. (Correct response)
- The price of gasoline was predicted to be about \$3.77 at the end of 2013.

Domain	S—Statistics & Probability
Subdomain	S.ID—Interpreting Categorical and Quantitative Data
Standard	S.ID.9: Distinguish between correlation and causation.
Emphasis Level	Medium
Evidence Statement	The examinee will demonstrate an understanding by distinguishing between correlation and causation in presented contexts.
Assessment Limits / Content Constraints	<ul style="list-style-type: none"> • Context is required. • Stimulus should be a verbal description or a graph or a scatter plot with or without a trend line.
DOK(s)	1, 2, or 3
Sample Item Stem(s)	Which conclusion can be drawn from this data?

Sample Item

The Centers for Disease Control and Prevention (CDC) has provided a graph that groups students by the grades they earned. It shows the percentage of high school students in each group who drank soda at least one time per day.

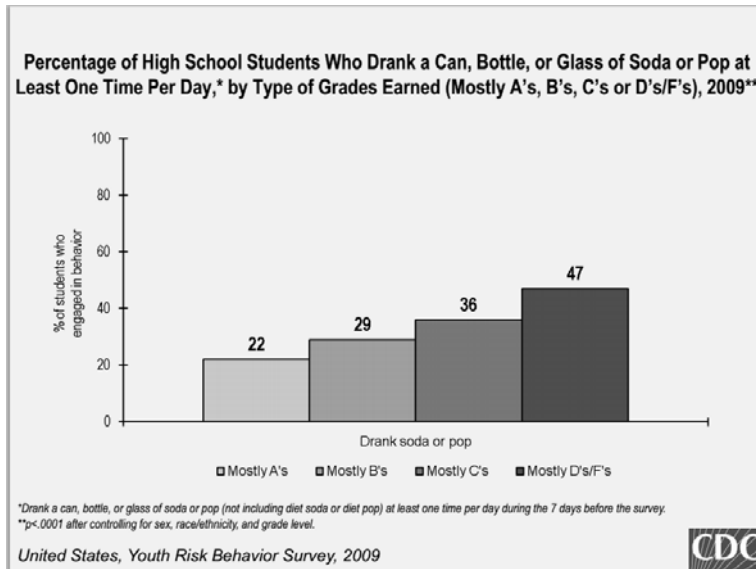

Which conclusion can be drawn about the relationship between drinking soda and getting poor grades?

- A. Drinking soda causes students to earn poor grades.
- B. Getting poor grades more likely causes students to drink soda.
- C. There is a correlation between drinking soda and earning poor grades. (Correct response)
- D. There is no relationship between drinking soda and earning poor grades.

4) Other Mathematics Subtest Specifications

a) Scoring Rules

Multiple-Choice (MC) Items

MC items have four answer options with a single correct response. These items are worth 1 point each. An examinee receives 1 point for a correct response and 0 points for an incorrect response.

Gridded Response (GR) Items

GR items require examinees to provide a numeric response. In print, an examinee writes the response in a grid with one character per box and then fills in the bubble beneath each box corresponding with the number or character in the box. Online, an examinee types the response in a box. These items are worth 1 point each. An examinee receives 1 point for a correct response and 0 points for an incorrect response. A sample print grid is shown below.

	/	/	/	
•	•	•	•	•
0	0	0	0	0
1	1	1	1	1
2	2	2	2	2
3	3	3	3	3
4	4	4	4	4
5	5	5	5	5
6	6	6	6	6
7	7	7	7	7
8	8	8	8	8
9	9	9	9	9

Autoscored Items

Autoscored item types that are offered on both print and online forms are included in the TASC subtest in Mathematics. These item types include Multiple-Selected Response (MSR), Two-Part Multiple Choice, and Technology Enhanced items such as Drag and Drop (DND), Interactive Matching, and Dropdown List items. Autoscored items worth 1 point and autoscored items worth 2 points are included in both online and print forms. Technology Enhanced items (which appear only online) have companion items on the print forms. These companion items are presented as MSR or two-part multiple choice items such that the companion item assesses the same skill at the same level of rigor as the TE item. An examinee can receive partial credit for each of these item types as described below.

MSR

Multiple-Selected Response (MSR) items may ask examinees to identify two or three correct responses. When responding to items that have three correct answers, examinees will earn 2 points for identifying all three correct responses and 1 point for identifying two correct responses. An examinee will receive 0 points for identifying 0 or 1 correct responses. When responding to items that have two correct answers, examinees will receive 1 point for identifying both correct responses and 0 points for identifying 0 or 1 correct responses. Each MSR item in the Science subtest has six answer options. An examinee responds by selecting (filling in a bubble in the answer document or the online testing environment) up to the specified number of answer options, and each item indicates how many correct responses should be selected. MSR items appear in both print and online forms.

Two-Part Multiple Choice or Two-Part Multiple Select

A Two-Part Multiple Choice or Two-Part Multiple Select item is typically used as the print companion of a technology-enhanced item. As such, it may be worth 1 or 2 points, depending on the point value of the accompanying online item. If the item is worth 2 points, the scoring of the two parts is independent, and examinees may receive one point for each part.

DND

Drag and Drop (DND) items ask examinees to drag responses to two or more drop areas, or response areas. These items may be worth 1 or 2 points, depending on the number of responses that are expected. If a DND item is worth 2 points, an examinee will receive 2 points for a completely correct response and 1 point for a response that is at least 50% correct (e.g., if an examinee is asked to label a diagram by dragging each of four labels into the diagram, the examinee would receive 2 points for all four labels correctly placed, 1 point for 2-3 labels correctly placed, and 0 points for 0-1 labels correctly placed).

Interactive Matching

Interactive Matching items ask examinees to correctly classify each item of a list of two or more examples with a corresponding value in a second list (e.g. match an equation to a graph). These items may be worth 1 or 2 points, depending on the number of responses that are expected. If an Interactive Matching item is worth 2 points, an examinee will receive 2 points for a completely correct response and 1 point for a response that is at least 50% correct (e.g., if an examinee is asked to identify each of four expressions as positive, negative, or zero, the examinee would receive 2 points for correctly identifying all 4 expressions, 1 point for correctly labeling 2 or 3 expressions, and 0 points for correctly labeling 1 or 1 expression).

Dropdown List

Dropdown List items ask examinees to drag responses to two or more drop areas, or response areas. These items may be worth 1 or 2 points, depending on the number of responses that are expected. If a Dropdown List item is worth 2 points, an examinee will receive 2 points for a completely correct response and 1 point for a partially correct response (e.g., if an examinee is asked to complete two equations by selecting from dropdown lists within each equation, the examinee would receive 2 points for correctly completing both equations, 1 point for correctly completing one equation, and 0 points for not correctly completing either equation).

Constructed-Response (CR) Items

Constructed-Response (CR) items are worth 2 points. An examinee can receive either 2 points for fulfilling all the requirements for a correct response, 1 point for a partially correct response, or 0 points for a response that is completely irrelevant or completely incorrect. If no response is present, a condition code is assigned. Scoring rubrics are included in this document in the section following the specification tables.

A CR item can ask a question (e.g., How ...) or can prompt with a directive (e.g., Explain how...). A CR item may have more than one question or prompt, if necessary. A lead-in will typically have one paragraph of text (or less) and may have one or two graphics.

Analytic Scoring Rubrics

TASC Mathematics subtests use analytic rubrics that describe the type(s) of acceptable response(s) for each key element being scored. Typically, a CR item will require a separate key element for each score point. The rubric must be designed in such a way to allow each key element to be identified accurately, consistently, efficiently, and fairly across the full range of possible responses.

Each score point level should represent a distinct level of performance (i.e., a response awarded a score of 2 demonstrates additional knowledge and skills distinct from those demonstrated in a response awarded a score of 1, etc.). The question and rubric should avoid dependencies that create a “domino effect” where a response either gets everything correct or nothing correct. Partially correct responses (such as scoring 1 out of 2 points) must be possible to attain.

- Ensure that the CR item is eliciting responses that provide rich information about performance.
- If an actual response states the same idea in slightly different (but still accurate) wording, it will receive credit. The response does not necessarily have to match the exact wording in the rubric.
- For bulleted lists, indicate what quantity of responses (“any one”, “any two”, etc.) are needed to receive full credit.
- If necessary, include scoring note(s) to help clarify what responses are acceptable and/or how to award the key elements.
- The analytical scoring rubric for a sample CR items is included below.

TASC Mathematics 2-Point Analytic Scoring Rubric Sample

The side lengths of a trapezoid are marked as shown in the diagram.

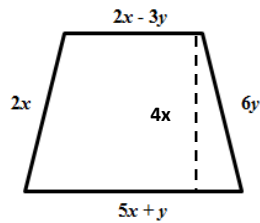

The area of a trapezoid is $A = \frac{1}{2}h(b_1 + b_2)$, where A = area, h = height, b_1 = base one, and b_2 = base two.

Using the fewest number of terms (simplest form), write an expression to represent the perimeter of the trapezoid.

Using the fewest number of terms (simplest form), write an expression to represent the area of the trapezoid.

b) Sample Scoring Rubric

Score point: 2
Scoring Criteria
Examinee finds the correct expression for the perimeter AND area using the fewest number of terms.
Exemplar for Score Point
$P = 9x + 4y$ or another equivalent expression AND $A = 14x^2 - 4xy$ or another equivalent expression (Examinees do not have to use " $P =$ " or " $A =$ " to receive full credit)
Score point: 1
Scoring Criteria
Examinee finds the correct expression for the perimeter OR area using the least number of terms.
Exemplar for Score Point
$P = 9x + 4y$ or another equivalent expression OR $A = 14x^2 - 4xy$ or another equivalent expression (Examinees do not have to use " $P =$ " or " $A =$ " to receive full credit)
Score point: 0
Scoring Criteria
Examinee does not attempt item or the response is completely irrelevant or completely incorrect.
Exemplar for Score Point
N/A

c) Calculation Specifications

Examinees should be able to and are expected to perform the following calculations **without a calculator**:

Addition:

- Up to 3 four-digit positive whole numbers or decimals
 Example: $3,601 + 2,567 + 23.16 =$
- Two integers with up to two-digits (including negatives)
 Examples: $-72 + 40 =$
 $15 + (-27) =$
- Two fractions with denominators up to 20
 Example: $\frac{3}{4} + \frac{11}{20} =$

Subtraction:

- Up to three-digit whole numbers or decimals
 Example: $3.17 - 1.86 =$
- Up to two-digit integers (negatives)
 Example: $-62 - 37 =$
- Fractions with denominators up to 20
 Example: $\frac{7}{8} - \frac{1}{4} =$

Multiplication:

- At most, a two-digit number times a three digit number (whole numbers or decimals)
 Example: $168 * 2.3 =$
- At most, a one-digit integer times a two-digit integer (negatives)
 Example: $-18 * 7 =$
- Two fractions with denominators up to 20
 Example: $\frac{3}{5} * \frac{2}{13} =$

Division:

At most, a one-digit divisor and up to a four-digit dividend (decimals or whole numbers)

Example: $\frac{417.4}{5} =$

- Fractions with denominators up to 20

Example: $\frac{\frac{5}{7}}{\frac{14}{15}} =$

All Algebra or Functions items will be included in the Calculator section unless the calculations required are one or two digits and are relatively simple.

d) Item/Stimuli Graphic Guidelines

Any art used should be necessary in order to answer the question. All the following are considered graphics: tables, charts, graphs, diagrams, pictures, etc.

Graphics used in stimuli or items must take into consideration the size limitations associated with the TASC art specifications. If a stimulus or item has one graphic, the maximum allowed size of the graphic is approximately 4.5 inches wide by 4.5 inches tall. If a stimulus or item has two graphics, then both graphics must fit together within this same maximum size (i.e., each graphic gets only half the maximum allowed space), whether they are vertically stacked or presented side-by-side.

e) Item Accessibility

In general, vocabulary within an item should be at or below the grade level being tested. The concept is being tested, not the examinee's ability to decipher the question. For TASC tests, vocabulary should be at the 9th-grade level.

Additional considerations include the following:

- Use plain, common language
- Avoid extraneous phrases and clauses
- Avoid including excessive data in stimuli
- Include clear titles and labels with all graphic stimuli
- Avoid using idioms (e.g., long time, leading edge, dry run, kitty-corner)
- Use simple, describable graphic stimuli (tables, graphs, charts, and diagrams)
- Avoid certain English word choices or phrases that may cause linguistic issues in translation and interpretation (e.g., billion, library, fabric, ton, deck of cards)